

Features

- Direct interface to C-MOS, TTL, etc.
- High-speed switching
- No secondary breakdown

Product Summary

| V_{DS} | $R_{DS(ON)}$ MAX | I_D MAX |
|----------|------------------|-----------|
| 50V | 3Ω@10V | 0.173A |
| | 4Ω@4.5V | |

Application

- Thin and thick film circuits
- General purpose fast switching applications

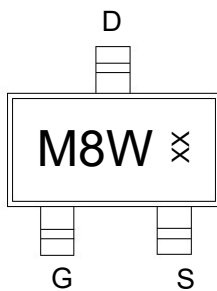

M8W: Device code
 XX: Code

Marking and pin assignment

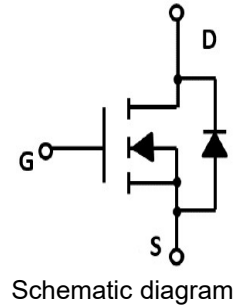
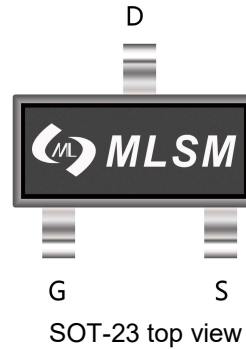

Halogen-Free

Absolute Maximum Ratings (TA=25°C unless otherwise noted)

| Symbol | Parameter | Rating | Unit |
|--------|-----------|--------|------|
|--------|-----------|--------|------|

Common Ratings (TC=25°C Unless Otherwise Noted)

| | | | |
|-----------|----------------------------------|---------------------------------|----|
| V_{DS} | Drain-Source Breakdown Voltage | 50 | V |
| V_{GS} | Gate-Source Voltage | ±20 | V |
| T_J | Maximum Junction Temperature | 150 | °C |
| T_{STG} | Storage Temperature Range | -50 to 155 | °C |
| I_S | Diode Continuous Forward Current | $T_c=25^\circ\text{C}$ 0.173 | A |

Mounted on Large Heat Sink

| | | | |
|-----------------|--|---------------------------------|------|
| I_{DM} | Pulse Drain Current Tested | $T_c=25^\circ\text{C}$ 0.7 | A |
| I_D | Continuous Drain Current | $T_c=25^\circ\text{C}$ 0.173 | A |
| P_D | Maximum Power Dissipation | $T_c=25^\circ\text{C}$ 0.83 | W |
| $R_{\theta JA}$ | Thermal Resistance Junction-to-Ambient | 350 | °C/W |

Ordering Information (Example)

| Type | Package | Marking | Minimum Package(pcs) | Inner Box Quantity(pcs) | Outer Carton Quantity(pcs) | Delivery Mode |
|-------|---------|---------|----------------------|-------------------------|----------------------------|---------------|
| BSN20 | SOT-23 | M8W | 3,000 | 45,000 | 180,000 | 7"reel |

| Electrical Characteristics (T _J =25°C unless otherwise noted) | | | | | | |
|--|----------------------------------|---|-----|------|------|------|
| Symbol | Parameter | Condition | Min | Typ | Max | Unit |
| Static Electrical Characteristics @ T_J = 25°C (unless otherwise stated) | | | | | | |
| BV _{(BR)DSS} | Drain-Source Breakdown Voltage | V _{GS} =0V, I _D =250μA | 50 | -- | -- | V |
| I _{DSS} | Zero Gate Voltage Drain Current | V _{DS} =50V, V _{GS} =0V | -- | -- | 1 | μA |
| I _{GSS} | Gate-Body Leakage Current | V _{GS} =±20V, V _{DS} =0V | -- | -- | ±100 | nA |
| V _{GS(th)} | Gate Threshold Voltage | V _{DS} =V _{GS} , I _D =250μA | 0.4 | 0.67 | 1.5 | V |
| R _{DS(on)} | Drain-Source On-State Resistance | V _{GS} =10V, I _D =0.3A | -- | 1.27 | 3 | Ω |
| | | V _{GS} =4.5V, I _D =0.1A | -- | 1.31 | 4 | Ω |
| Dynamic Electrical Characteristics @ T_J = 25°C (unless otherwise stated) | | | | | | |
| C _{ISS} | Input Capacitance | V _{DS} =25V, V _{GS} =0V, f=1MHz | -- | 28.5 | -- | pF |
| C _{OSS} | Output Capacitance | | -- | 2.7 | -- | pF |
| C _{RSS} | Reverse Transfer Capacitance | | -- | 1.78 | -- | pF |
| Switching Characteristics | | | | | | |
| Q _g | Total Gate Charge | V _{DS} =25V, I _D =0.3A, V _{GS} =10V | -- | 1.7 | -- | nC |
| Q _{gs} | Gate Source Charge | | -- | 0.4 | -- | nC |
| Q _{gd} | Gate Drain Charge | | -- | 0.24 | -- | nC |
| t _{d(on)} | Turn-on Delay Time | V _{DD} =25V, I _D =0.3A, V _{GS} =10V, R _G =6Ω | -- | 2.6 | -- | nS |
| t _r | Turn-on Rise Time | | -- | 18.8 | -- | nS |
| t _{d(off)} | Turn-Off Delay Time | | -- | 9.7 | -- | nS |
| t _f | Turn-Off Fall Time | | -- | 47 | -- | nS |
| Source- Drain Diode Characteristics | | | | | | |
| V _{SD} | Forward on voltage | T _J =25°C, I _S =0.1A | -- | -- | 1.2 | V |

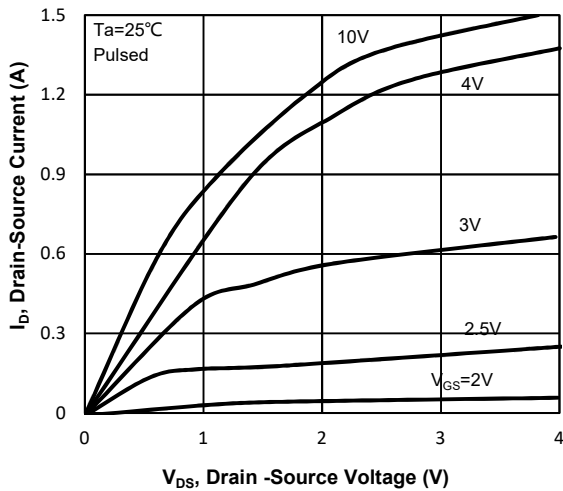
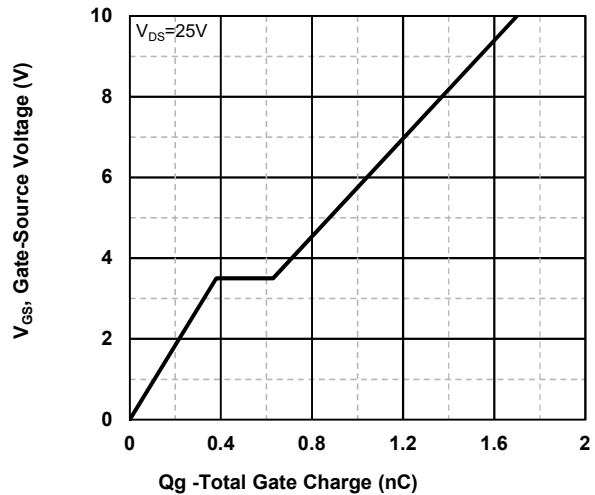
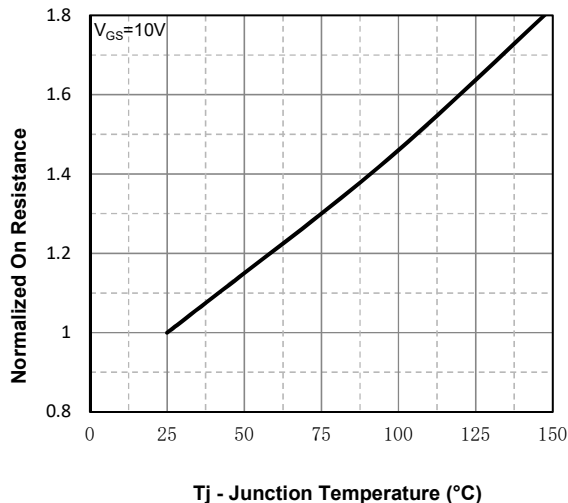
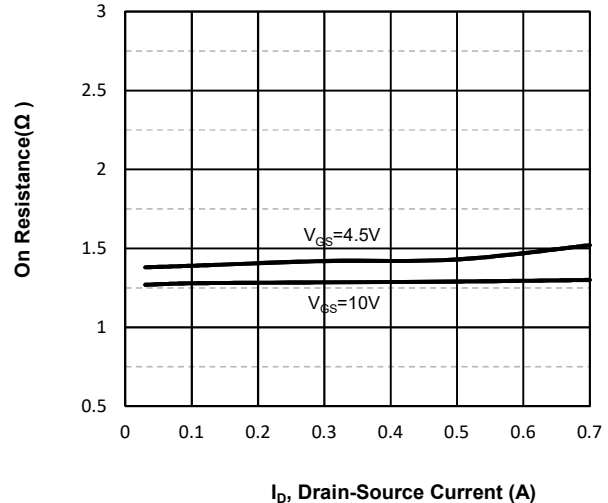
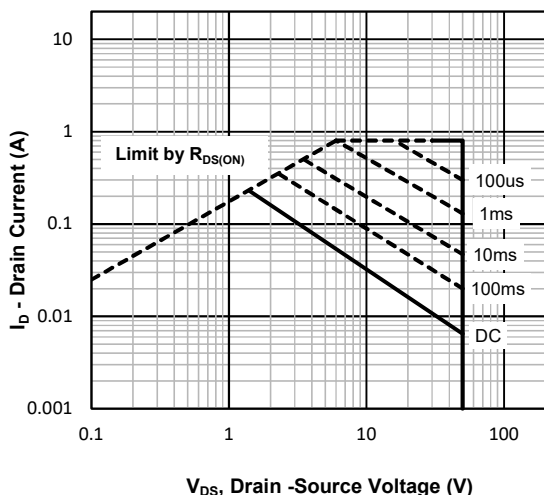
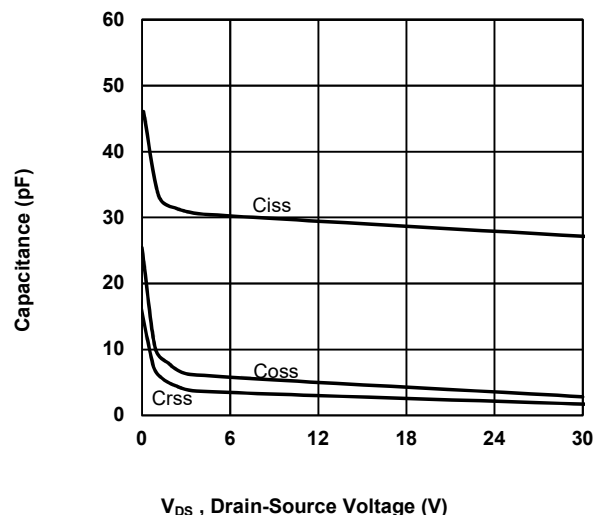
Typical Operating Characteristics

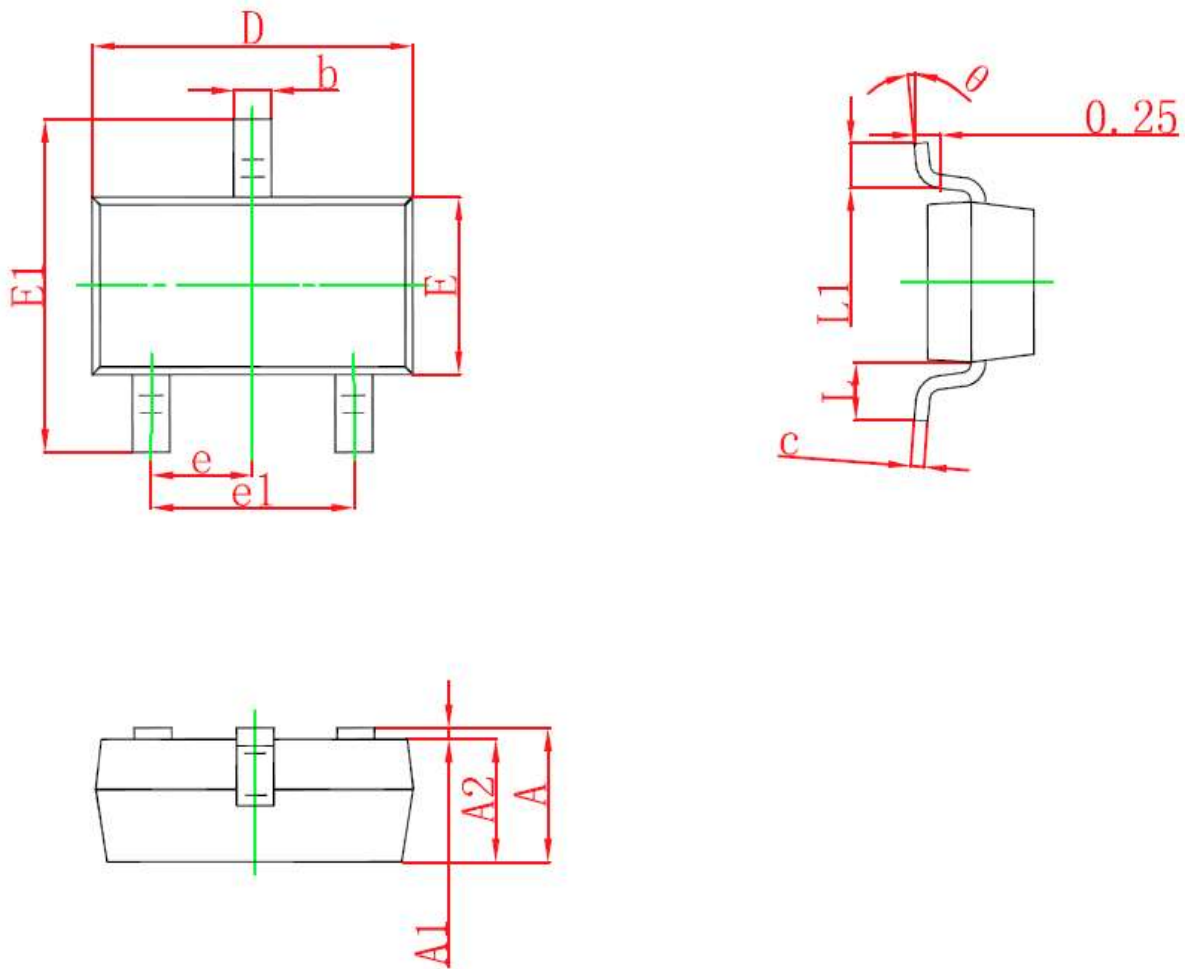
Fig1. Typical Output Characteristics

Fig2. Typical Gate Charge Vs. Gate-Source Voltage

Fig3. Normalized On-Resistance Vs. Temperature

Fig4. On-Resistance Vs. Drain-Source Current

Fig5. Maximum Safe Operating Area

Fig6 Typical Capacitance Vs. Drain-Source Voltage

SOT-23 Package information

| Symbol | Dimensions in Millimeters(mm) | | Dimensions In Inches | |
|--------|-------------------------------|-------|----------------------|-------|
| | Min | Max | Min | Max |
| A | 0.900 | 1.150 | 0.035 | 0.045 |
| A1 | 0.000 | 0.100 | 0.000 | 0.004 |
| A2 | 0.900 | 1.050 | 0.035 | 0.041 |
| b | 0.300 | 0.500 | 0.012 | 0.020 |
| c | 0.080 | 0.150 | 0.003 | 0.006 |
| D | 2.800 | 3.000 | 0.110 | 0.118 |
| E1 | 2.250 | 2.550 | 0.088 | 0.100 |
| E | 1.200 | 1.400 | 0.047 | 0.055 |
| e | 0.950TYP | | 0.037TYP | |
| e1 | 1.800 | 2.000 | 0.071 | 0.079 |
| L | 0.550 REF | | 0.022 REF | |
| L1 | 0.300 | 0.500 | 0.012 | 0.020 |
| θ | 0° | 8° | 0° | 8° |