

Features

- Supply voltage: 2.7 V to 5.5 V
- Input offset voltage: 5 mV maximum
- Unity-gain bandwidth: 1.5 MHz
- Slew rate: 0.7 V/μs
- Low quiescent power consumption: 100 μA per channel
- Rail-to-rail input and output
- Low 1/f noise: 22 nV/√Hz @ 1 kHz
- Wide operating temperature range: -40 °C to 125 °C

Application

- Wireless Devices
- Instruments and Meters / Test and Measurement Instruments
- Motor Control
- Industrial Control
- Low-Side Current Sensing and Sampling

Description

The LMV321B/LMV358B/LMV324B series are CMOS rail-to-rail input and output (RRIO) operational amplifiers with low offset voltage, low power consumption and stable high-frequency response.

By adopting proprietary and patented design technologies, they deliver excellent AC performance with a 1.5 MHz bandwidth, 0.7 V/μs slew rate and low distortion, while consuming only 100μA quiescent current per amplifier.

The input common-mode voltage range extends 100mV beyond V₋ and V₊, with rail-to-rail output swing.

Available in industry-standard compact packages, these devices can replace standard operational amplifiers to reduce power consumption and enhance input/output range as well as overall performance.



Halogen-Free

Ordering Information (Example)

Type	Package	Marking	Minimum Package(pcs)	Inner Box Quantity(pcs)	Outer Carton Quantity(pcs)	Delivery Mode
LMV321B	SOT-353	21B	3,000	45,000	180,000	7"reel
	SOT-23-5L	321B	3,000	45,000	180,000	7"reel
LMV358B	SOP8	358D	4,000	8,000	56,000	13"reel
	TSSOP-8	358PW	5,000	10,000	70,000	13"reel
	MSOP-8	358DK	4,000	8,000	56,000	13"reel
LMV324B	SOP-14	324D	4,000	8,000	56,000	13"reel
	TSSOP-14	324PW	3,000	6,000	42,000	13"reel

Typical Application Circuit

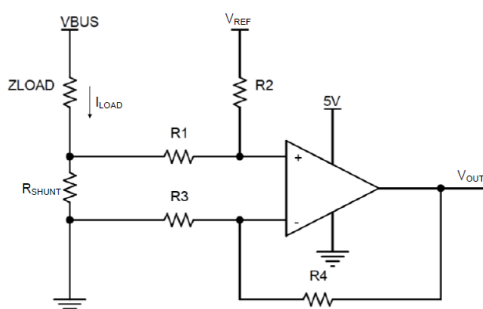

$$V_{OUT} = (I_{LOAD} \cdot R_{SHUNT}) \cdot (R4/R3) + V_{REF}$$

$$R3 = R1 \quad R2 = R4 \quad R_{SHUNT} \ll R1$$

Block Diagram

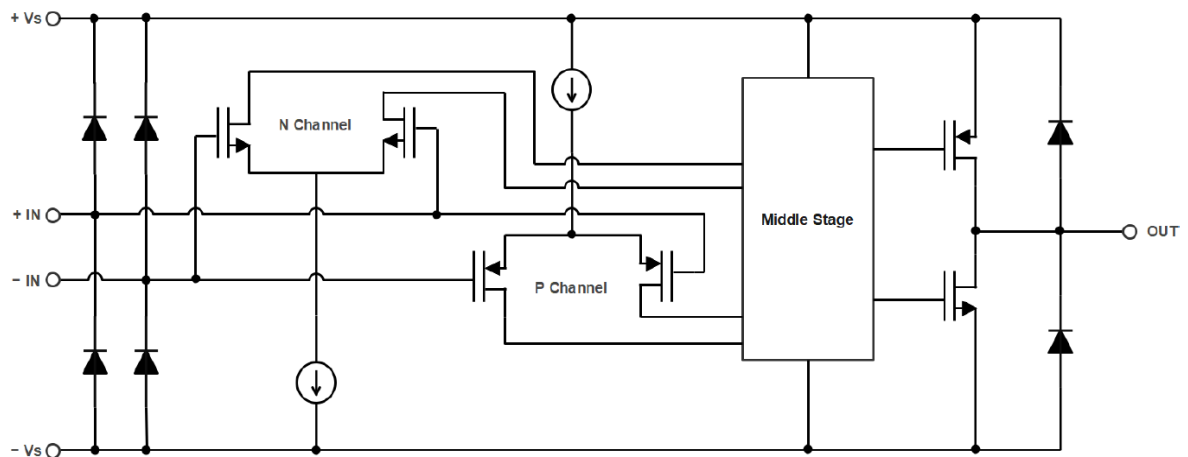

Pin Configuration and Functions

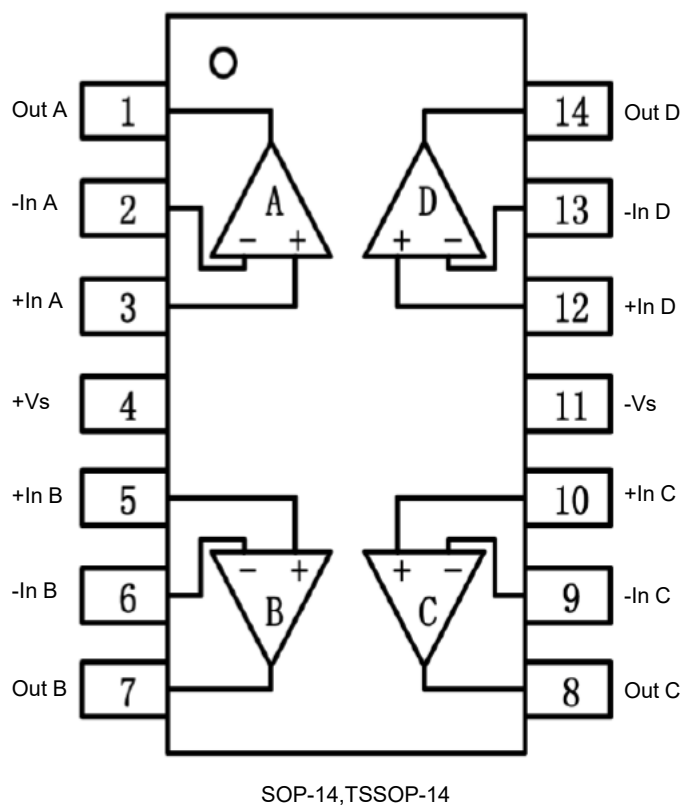
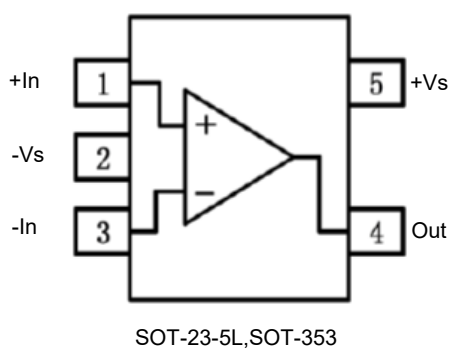
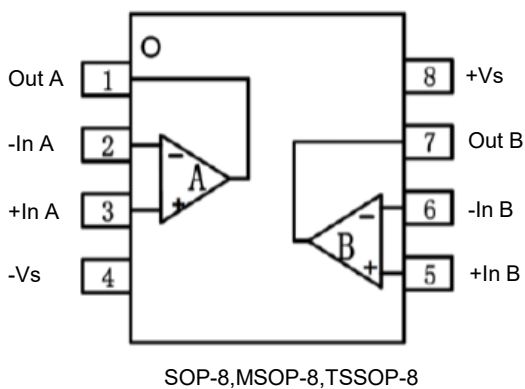

Pin	Description
Out A, Out B, Out C, Out D,Out	Amplifier Output
-In A, -In B, -In C, -In D, -In	Amplifier Negative Input
+In A, +In B, +In C, +In D, +In	Amplifier Positive Input
-Vs	Negative Power Supply or Power Supply Reference Ground
+Vs	Positive Power Supply or Power Supply

Absolute Maximum Ratings

Parameter Name	Symbol	Minimum	Maximum	Unit
Power Supply Voltage	(+Vs)-(-Vs)	2.7	5.5	V
Input Voltage	Vi	(-Vs)-0.3	(+Vs)+0.5	V
Differential Input Voltage	Vid	(-Vs)-(+Vs)	(+Vs)-(-Vs)	V
Input Current	Iin	-10	10	mA
Output Voltage	Vout	(-Vs)-0.3	(+Vs)+0.3	V
Output Short-Circuit Duration	-	-	Unlimited	S
Operating Ambient Temperature	TA	-40	125	°C
Operating Junction Temperature	TJ	-	150	°C
Storage Temperature	TS	-65	150	°C
Soldering Temperature (Welding Time 10s)	TL	-	260	°C

(1) Exceeding the listed parameter value range may cause permanent internal failure of the chip, and long-term operation under extreme conditions may affect the reliability of the chip.

(2) The input port is protected by ESD diodes clamped to the power supply terminal. When the input voltage exceeds the supply voltage, the input current must be limited to less than 10 mA.

(3) Output short circuit will cause high heating power of the chip. The short-circuit duration mainly depends on heat dissipation conditions, and high temperature may cause damage to the chip.

ESD Ratings

Symbol	Parameter	Condition	Minimum Level	Unit
HBM	Human Body Model ESD	ANSI/ESDA/JEDEC JS-001	6	kV
CDM	Charged Device Model ESD	ANSI/ESDA/JEDEC JS-002	1.5	kV

Recommended Operating Conditions

Operating temperature range(25°C) (unless otherwise noted)

Parameter Name	Symbol	Min	Max	Unit
Supply Voltage	(+VS)-(-VS)	2.7	5.5	V
Operating Ambient Temperature	TA	-40	125	°C

Thermal Characteristics

Package Type	θJA	θJC	Unit
SOT-353	400	-	°C/W
SOT-23-5L	232	81	
SOP-8	158	43	
MSOP-8	210	45	
TSSOP-8	190	44	
SOP-14	120	36	
TSSOP-14	180	35	

Electrical Characteristics

TA =25°C, Vs = 5V, RL = 10 kΩ ,unless otherwise noted

Parameter	Description	Conditions	Min	Typ	Max	Unit
VS	Supply Voltage	-	2.7	-	5.5	V
IQ	Quiescent Current per Amplifier	-	-	100	160	μA
		TA=-40 °C to 125°C	-	-	190	μA
PSRR	Power Supply Rejection Ratio	VS=2.5 V to 5.5 V	80	110	-	dB
		VS=2.5 V to 5.5 V,TA=-40 °C to 125°C	75	-	-	dB
VOS	Input Offset Voltage	VCM=0 V to 3 V	1	1.2	5	mV
		VCM=0 V to 3 V,TA=-40 °C to 125°C	0.15	-	5.6	mV
		VCM=3 V to 5 V	-5	1.2	7.4	mV
		VCM=3 V to 5 V,TA=-40 °C to 125°C	-5.6	-	11	mV
VOS TC	Input Offset Voltage Drift (1)	-	-	1	-	μV/°C
IB	Input Bias Current (1)	VCM=2.5 V	-300	10	300	pA
		VCM=2.5 V,TA=-40 °C to 125°C	-5	-	5	nA
IOS	Input Offset Current (1)	VCM=2.5 V	-300	10	300	pA
		VCM=2.5 V,TA=-40 °C to 125°C	-5	-	5	nA
CIN	Input Capacitance (2)	Differential Mode	-	6	-	pF
		Common Mode	-	8	-	pF
AV	Open-Loop Voltage Gain	VO=0.1 V to 4.9 V	80	100	-	dB
		VO=0.1 V to 4.9 V,TA=-40 °C to 125°C	75	-	-	dB
VCMR	Common-Mode Input Range	TA=-40 °C to 125°C	(-VS)-0.1	-	(+VS)+0.1	V
CMRR	Common-Mode Rejection Ratio	VCM=0 V to 5 V	60	80	-	dB
		VCM=0 V to 5 V,TA=-40 °C to 125°C	55	-	-	dB
		VCM=0 V to 3 V	85	110	-	dB
		VCM=0 V to 3 V,TA=-40 °C to 125°C	80	-	-	dB
VOH	High-Level Output Voltage Swing	-	-	10	15	mV
		-	-	-	20	mV
VOL	Low-Level Output Voltage Swing	-	-	10	15	mV
		-	-	-	20	mV
ISC	Output Short-Circuit Current	Sourcing or Sinking	70	90	-	mA
		Sourcing or Sinking, TA=-40 °C to 125°C	60	-	-	mA
GBW	Gain-Bandwidth Product (1)	-	1.5	-	-	MHz
SR	Slew Rate (1)	G=1,2V step	-	0.7	-	V/μs
tr	Rise Time (0.1%) (1)	G=1,2V step	-	4.3	-	ns
tf	Fall Time (0.01%) (1)	G=1,2V step	-	5.4	-	ns
PM	Phase Margin (1)	-	73	-	-	°
GM	Gain Margin (1)	-	15	-	-	dB
EN	Input Voltage Noise (1)	f=0.1Hz to 10Hz	-	2.1	-	μVRMS
en	Input Voltage Noise Density (1)	f=1kHz	-	22	-	nV/√Hz
iN	Input Current Noise (1)	f=1kHz	-	2	-	fA/√Hz
THD+N	Total Harmonic Distortion + Noise (2)	-	-	0.002	-	%

(1) Design support and platform test provided.

(2) Design simulation provided.

Typical Characteristics

TA = 25°C, Vs = 5V, VCM = 2.5V, unless otherwise noted

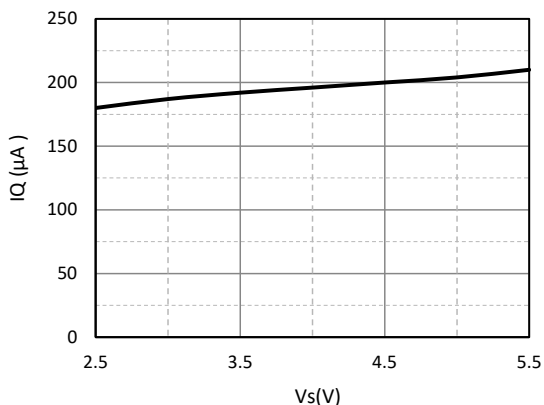

Figure 1. Quiescent Current VS Supply Voltage

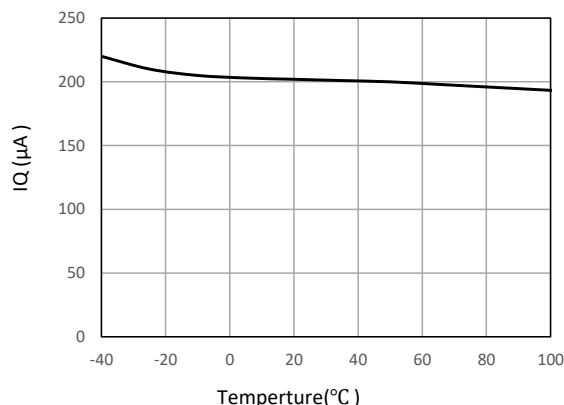

Figure 2. Quiescent Current VS Temperature

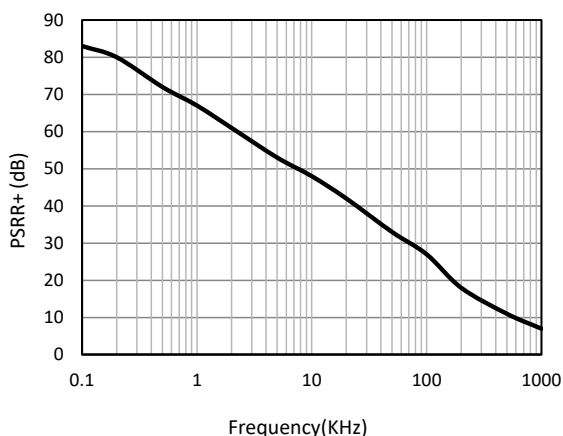

Figure 3. PSRR+ VS Frequency

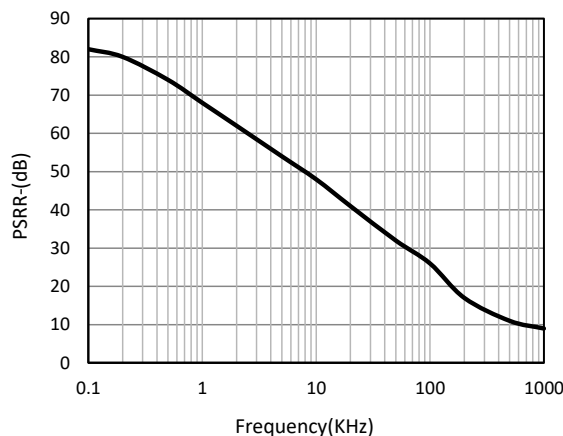

Figure 4. PSRR- VS Frequency

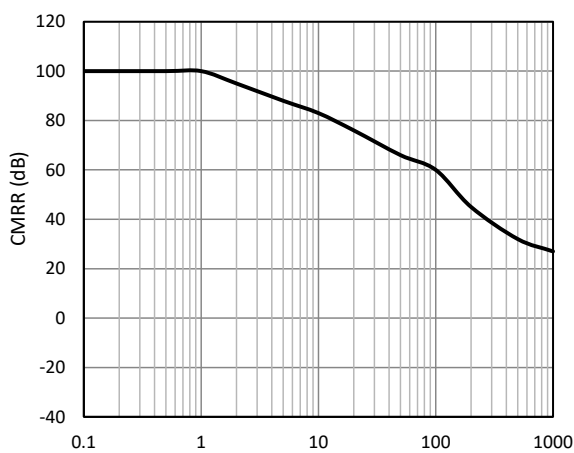

Figure 5. CMRR VS Frequency

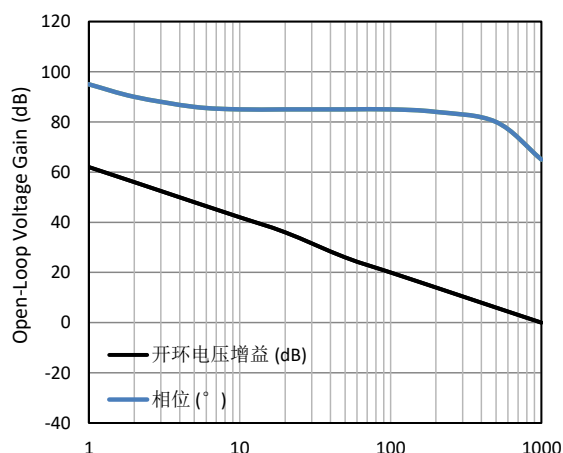

Figure 6. Open-Loop Gain and Phase VS Frequency

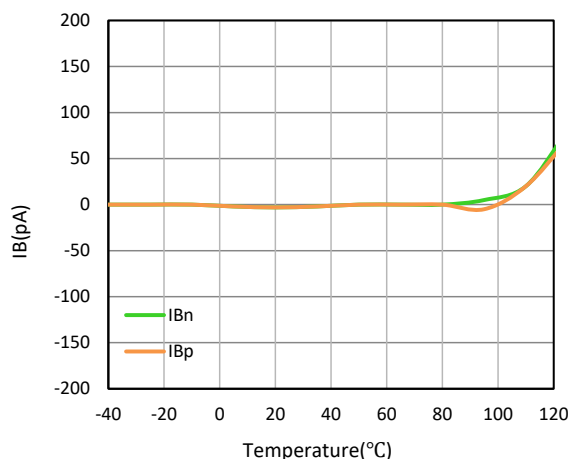

Figure 7. Input Bias Current vs. Temperature

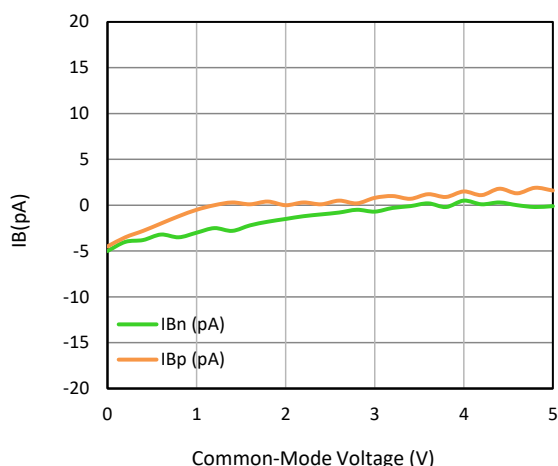

Figure 8. Input Bias Current vs. Common-Mode Voltage

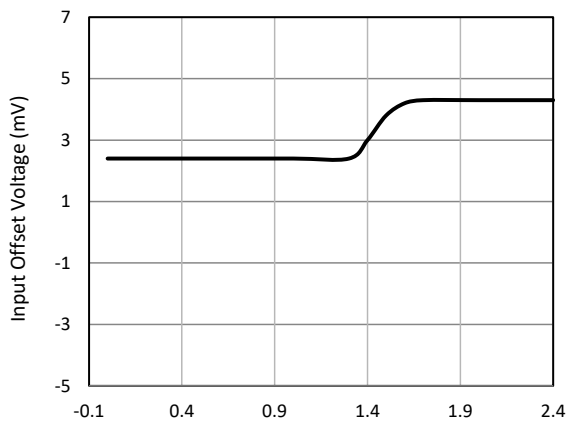

Figure 9. Input Offset Voltage VS Common-Mode Voltage(2.5V Supply)

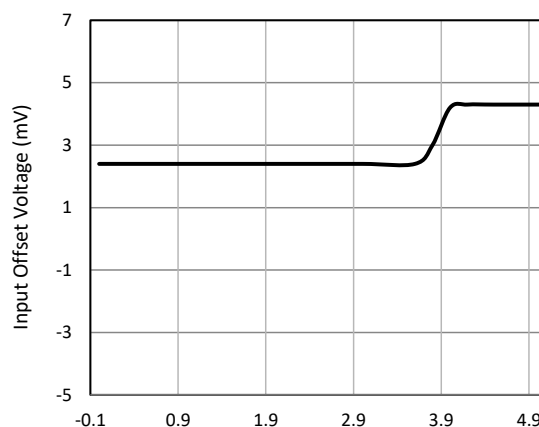

Figure 10. Input Offset Voltage VS Common-Mode Voltage(5V Supply)

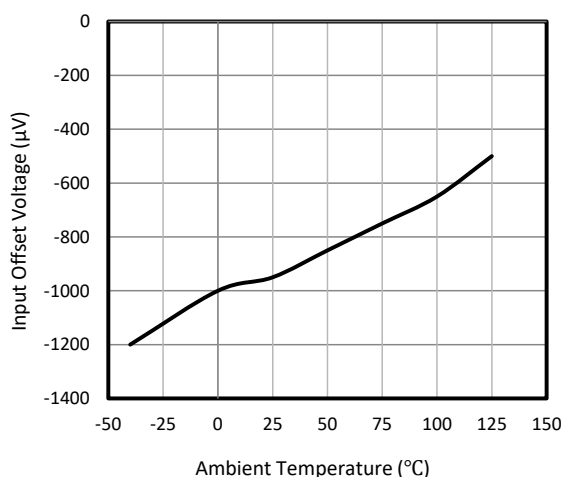

Figure 11. Input Offset Voltage vs. Ambient Temperature

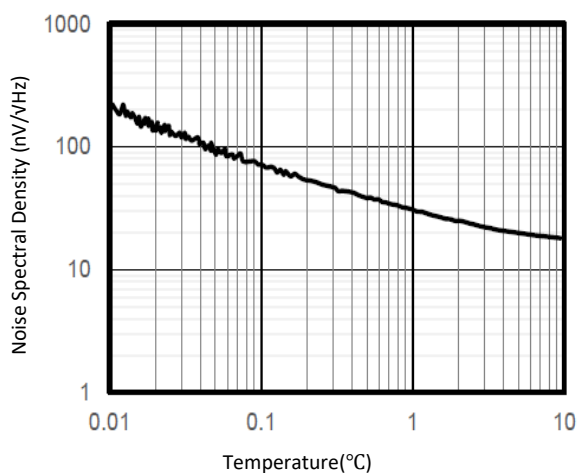

Figure 12. Input Voltage Noise Spectral Density vs. Frequency

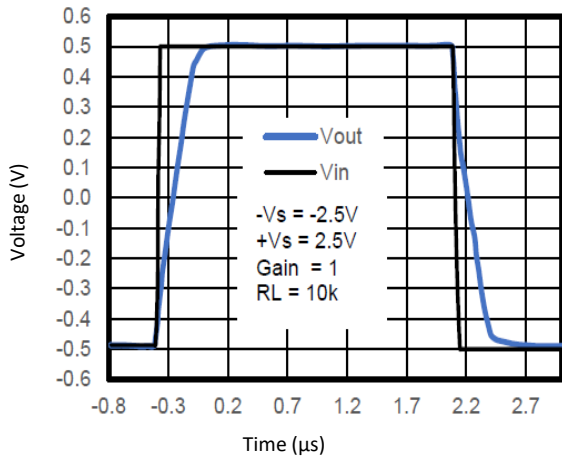

Figure 13. Large-Signal Step Response

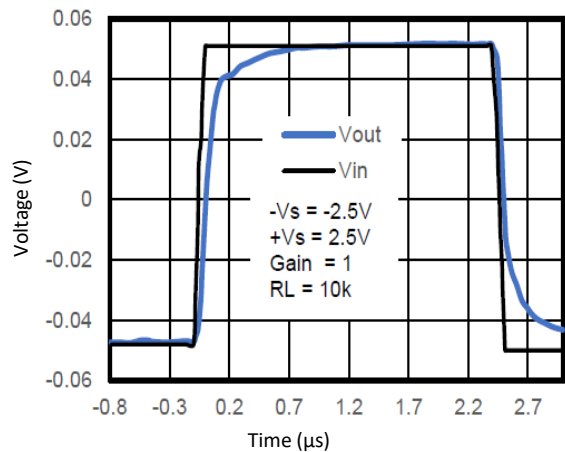

Figure 14. Small-Signal Step Response

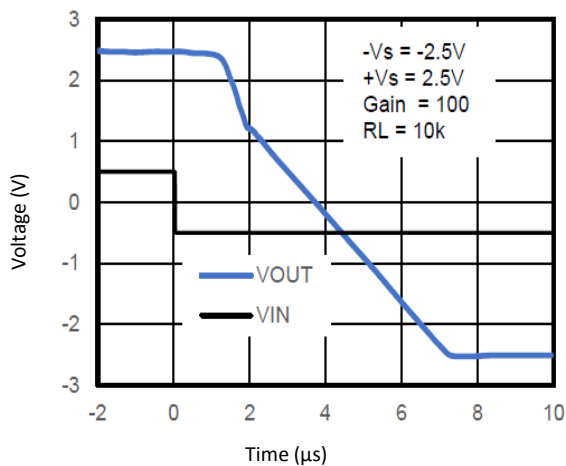

Figure 15. Overload Recovery (Falling Edge)

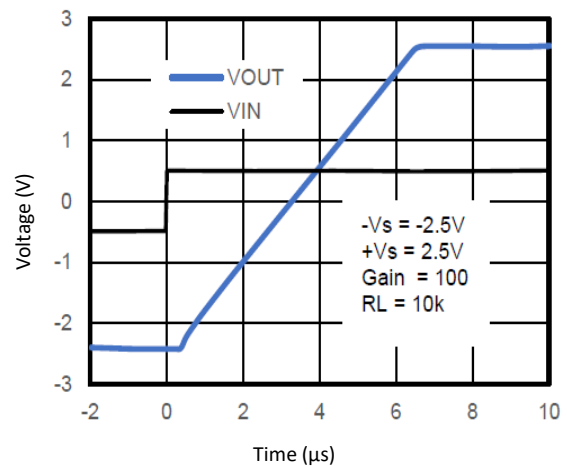

Figure 16. Overload Recovery (Rising Edge)

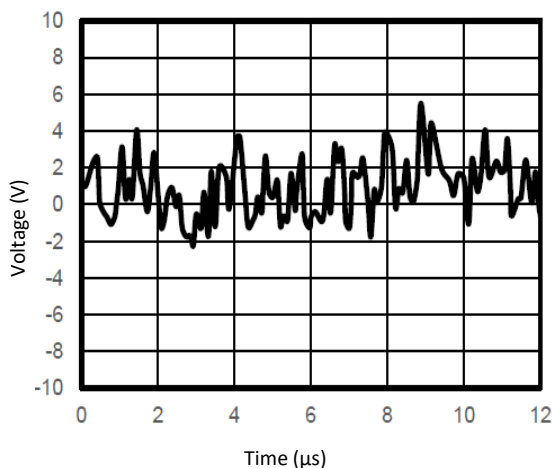
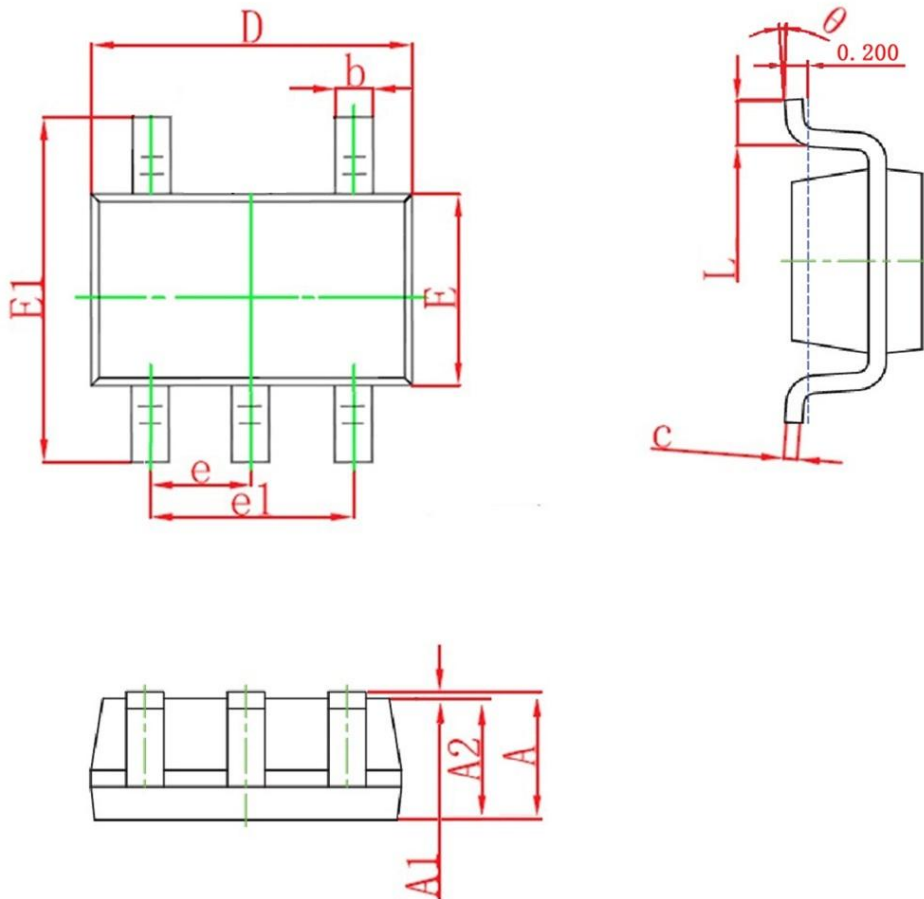
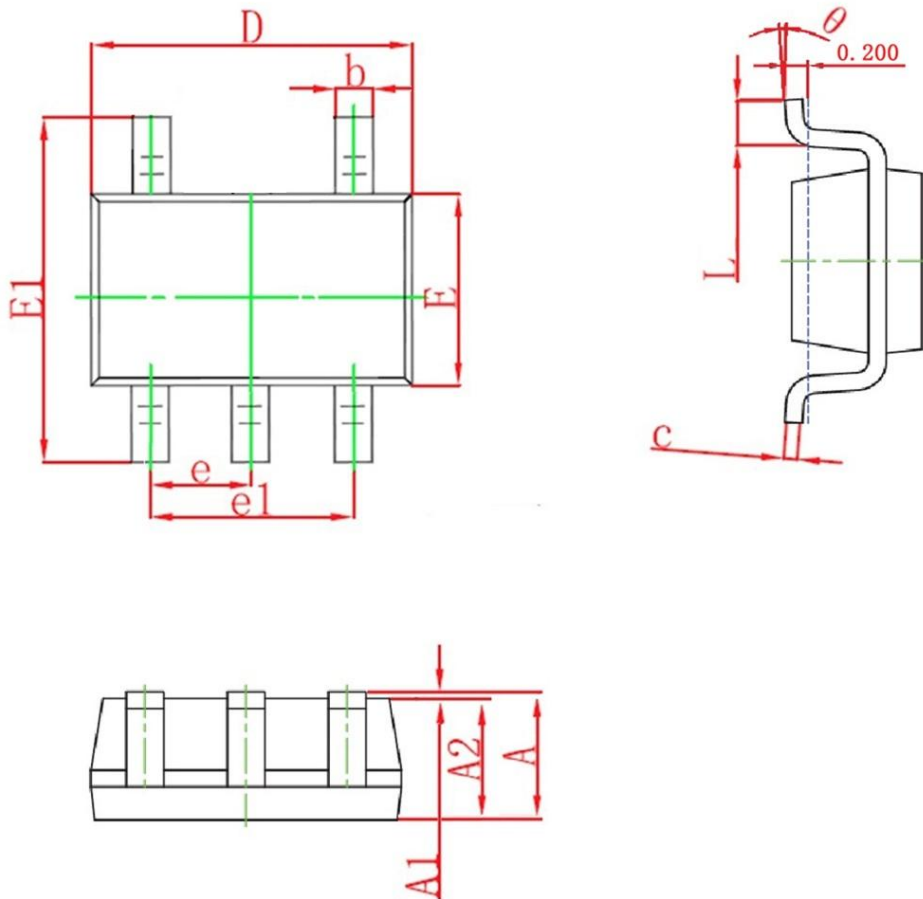

Figure 15. Overload Recovery (Falling Edge)

SOT-353 Package Outline Dimensions

Symbol	Dimensions in Millimeters(mm)		Dimensions In Inches	
	Min	Max	Min	Max
A	0.900	1.100	0.035	0.043
A1	0.000	0.100	0.000	0.004
A2	0.900	1.000	0.035	0.039
b	0.150	0.350	0.006	0.014
c	0.100	0.150	0.004	0.006
D	2.000	2.200	0.079	0.087
E	1.150	1.350	0.045	0.053
E1	2.150	2.400	0.085	0.094
e	0.650TYP		0.026TYP	
e1	1.200	1.400	0.047	0.055
L	0.525REF		0.021REF	
L1	0.260	0.460	0.010	0.018
θ	0°	8°	0°	8°

SOT-23-5L Package Outline Dimensions

Symbol	Dimensions in Millimeters(mm)		Dimensions in Inches	
	Min	Max	Min	Max
A	1.050	1.250	0.041	0.049
A1	0.000	0.100	0.000	0.004
A2	1.050	1.150	0.041	0.045
b	0.300	0.500	0.012	0.020
c	0.100	0.200	0.004	0.008
D	2.820	3.020	0.111	0.119
E	1.500	1.700	0.059	0.067
E1	2.650	2.950	0.104	0.116
e	0.950TYP		0.037TYP	
e1	1.800	2.000	0.071	0.079
L	0.300	0.600	0.012	0.024
θ	0°	8°	0°	8°

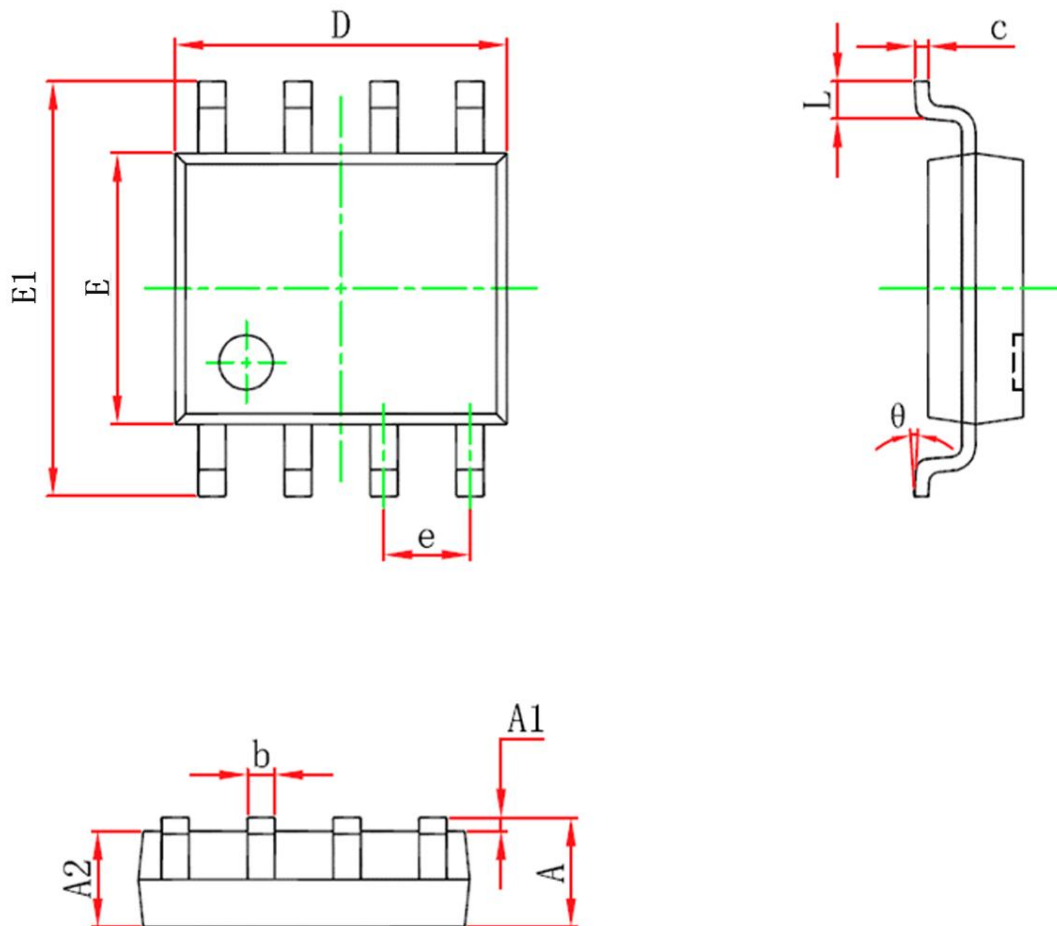
SOP-8 Package Outline Dimensions

Symbol	Dimensions in Millimeters(mm)		Dimensions In Inches	
	Min	Max	Min	Max
A	1.450	1.750	0.057	0.068
A1	0.100	0.250	0.003	0.009
A2	1.350	1.550	0.053	0.061
b	0.330	0.510	0.012	0.020
c	0.170	0.250	0.006	0.009
D	4.700	5.100	0.185	0.200
e	1.270(BSC)		0.050(BSC)	
E	3.800	4.000	0.149	0.157
E1	5.800	6.200	0.228	0.244
L	0.400	1.270	0.015	0.050
theta	0°	8°	0°	8°

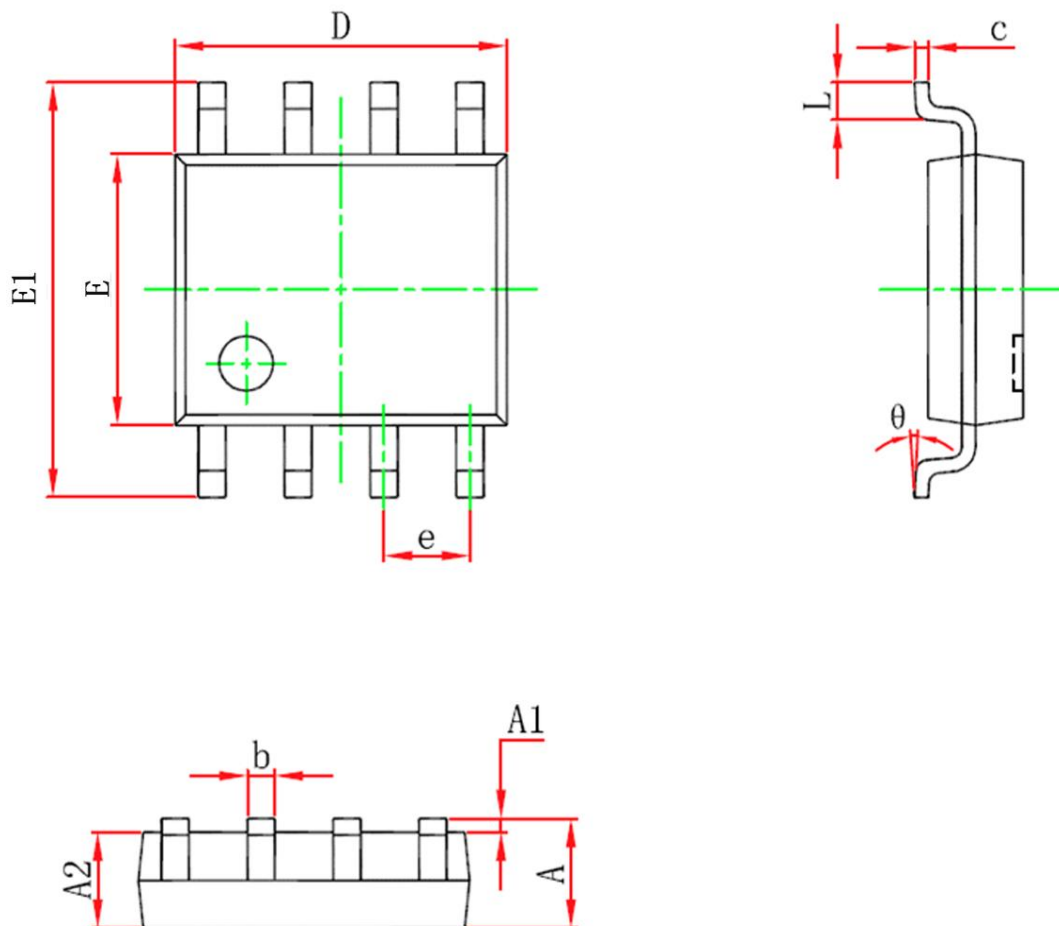
MSOP-8 Package Outline Dimensions

Symbol	Dimensions in Millimeters(mm)		Dimensions In Inches	
	Min	Max	Min	Max
A	0.800	1.100	0.031	0.043
A1	0.020	0.150	0.000	0.005
A2	0.750	0.950	0.029	0.037
b	0.250	0.380	0.009	0.014
c	0.090	0.230	0.003	0.009
D	0.290	0.310	0.011	0.012
e	0.650(BSC)		0.026(BSC)	
E	2.900	3.100	0.114	0.122
E1	4.700	5.100	0.185	0.200
L	0.400	0.800	0.015	0.031
θ	0°	8°	0°	8°

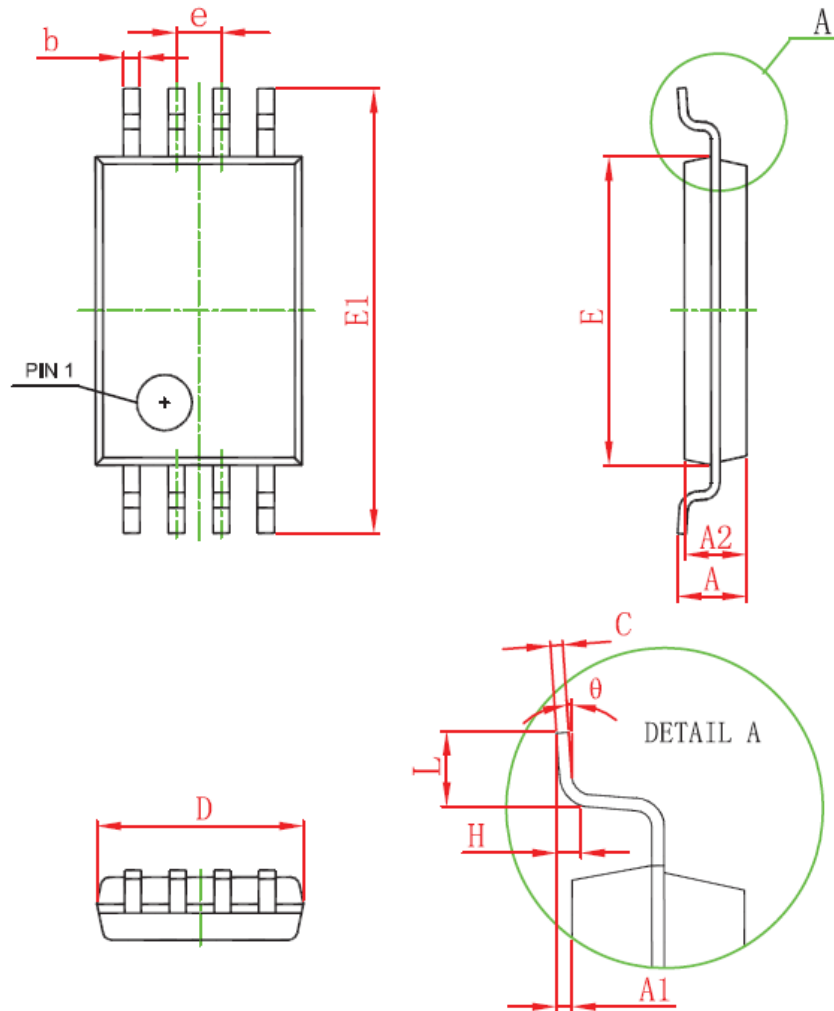
TSSOP-8 Package Outline Dimensions

Symbol	Dimensions in Millimeters(mm)		Dimensions in Inches	
	Min	Max	Min	Max
A	1.000	1.200	0.039	0.047
A1	0.020	0.180	0.000	0.007
A2	0.900	1.100	0.035	0.043
b	0.170	0.270	0.006	0.010
c	0.122	0.132	0.004	0.005
D	2.870	3.070	0.112	0.120
e	0.65BSC		0.025BSC	
E	4.300	4.500	0.169	0.177
E1	6.200	6.600	0.244	0.259
L	0.400	0.800	0.015	0.031
L1	1.00BSC		0.039BSC	
$\varnothing 1$	0.500	0.700	0.001	0.027
θ	0°	10°	0°	10°

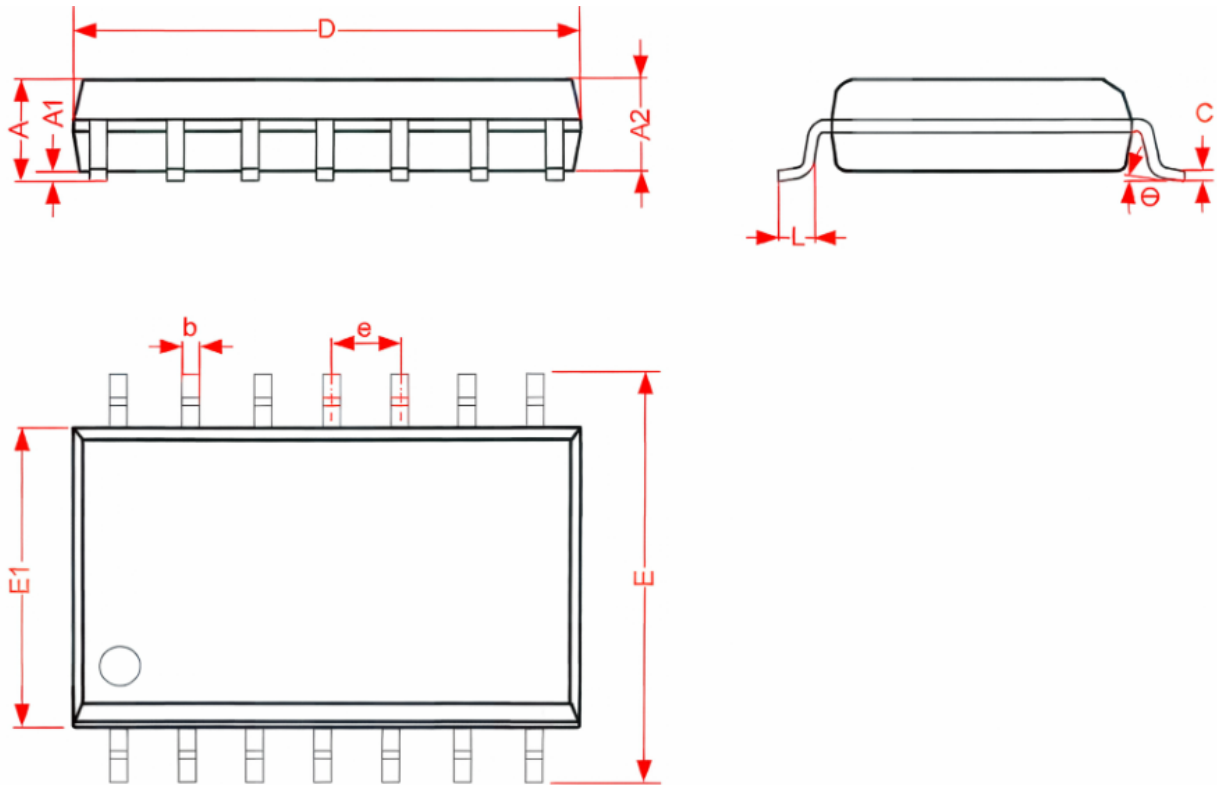
SOP-14 Package Outline Dimensions

Symbol	Dimensions in Millimeters(mm)		Dimensions In Inches	
	Min	Max	Min	Max
A	1.350	1.750	0.053	0.069
A1	0.050	0.250	0.002	0.010
A2	1.300	1.550	0.051	0.061
b	0.310	0.500	0.012	0.020
c	0.100	0.250	0.004	0.010
D	8.430	8.760	0.332	0.345
E	5.800	6.250	0.229	0.246
E1	3.750	4.000	0.148	0.158
e	1.270TYP		0.050TYP	
L	0.400	0.890	0.016	0.035
θ	0°	8°	0°	8°

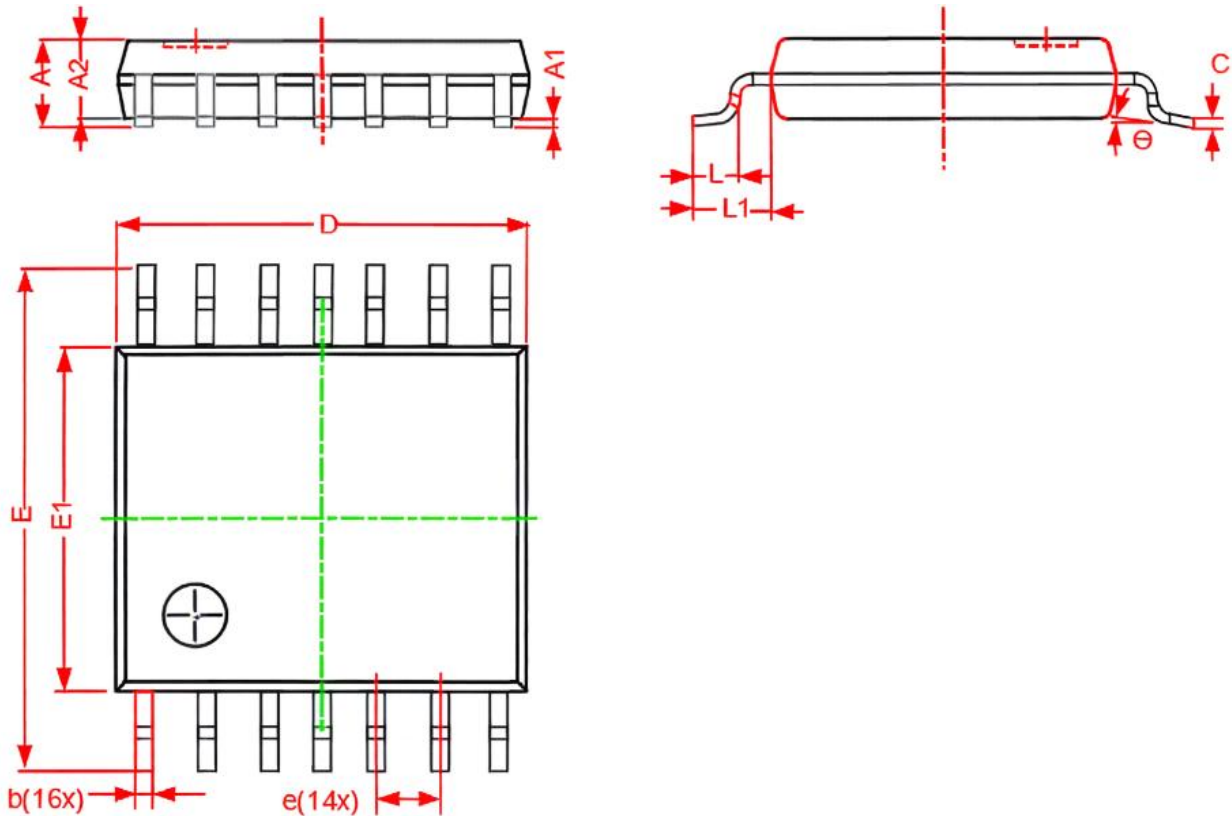
TSSOP-14 Package Outline Dimensions

Symbol	Dimensions in Millimeters(mm)		Dimensions In Inches	
	Min	Max	Min	Max
A	-	1.200	-	0.047
A1	0.050	0.150	0.002	0.006
A2	0.800	1.050	0.032	0.041
b	0.190	0.300	0.007	0.012
c	0.090	0.200	0.004	0.008
D	4.900	5.100	0.193	0.201
E	6.200	6.600	0.244	0.260
E1	4.300	4.500	0.169	0.177
e	0.650TYP		0.026TYP	
L1	1.00TYP		0.039TYP	
L	0.450	0.750	0.018	0.030
theta	0°	8°	0°	8°