

Features

- IGBT CHIP(Trench+Field Stop technology)
- Low Vcesat(typ) 1.6V@IC=40A
- Maximum junction temperature 175°C
- Low gate charge Qg
- RoHS compliant

Application

- DC-AC inverters
- Motion/servo control
- UPS systems

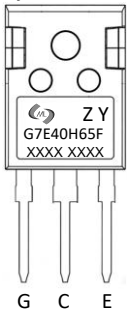

G7E40H65F : Device code
 XXXXXXXX : Code

Product Summary

V _{CE}	I _C (T _J =100°C)	V _{CE(sat)}
650V	40A	1.6V



TO-247 top view

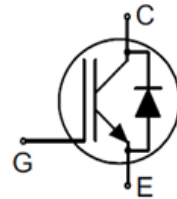

Schematic diagram



Halogen-Free

Marking and pin assignment

Absolute Maximum Ratings (TC=25°C unless otherwise noted)				
Symbol	Parameter	Rating	Unit	
Common Ratings (TC=25°C Unless Otherwise Noted)				
IGBT, Inverter				
V _{CES}	Collector Emitter Voltage	T _J =25°C	650	V
V _{GES}	Gate Emitter Voltage		±30	V
I _C	DC Collector Current	T _C =25°C	80	A
		T _C =100°C	40	A
I _{CRM}	Pulsed Collector Current, Limited by T _{vjmax}	tp=1ms	160	A
P _D	Power Dissipation	T _C =25°C	265.49	W
		T _C =100°C	132.74	W
Diode, Inverter				
V _{RRM}	Repetitive Reverse Voltage	T _J =25°C	650	V
I _F	Forward current, DC	T _C =25°C	80	A
		T _J =100°C	40	A
T _J , T _{stg}	Operating Junction and Storage Temperature Range		-55 to +175	°C

Ordering Information (Example)					
Type	Package	Marking	Minimum Package(pcs)	Inner Box Quantity(pcs)	Outer Carton Quantity(pcs)
MGA40H65F7	TO-247	G7E40H65F	30	270	2,160

IGBT, Inverter

Electrical Characteristics (TC=25°C unless otherwise noted)							
Symbol	Parameter	Condition	Min	Typ	Max	Unit	
Static Electrical Characteristics @ TC= 25°C (unless otherwise stated)							
$V_{GE(th)}$	Gate Emitter Threshold Voltage	$V_{CE}=V_{GE}, I_C=0.25mA$	4.5	5.0	6.0	V	
$V_{CE(sat)}$	Collector - Emitter Saturation Voltage	$I_C=40A, V_{GE}=15V, T_J=25°C$	--	1.6	2.1	V	
		$I_C=40A, V_{GE}=15V, T_J=150°C$	--	1.82	--	V	
I_{CES}	Collector Leakage Current	$V_{CE}=650V, V_{GE}=0V, T_J=25°C$	--	--	200	nA	
I_{GES}	Gate Leakage Current	$V_{CE}=0V, V_{GE}=20V, T_J=25°C$	--	--	200	nA	
Dynamic Electrical Characteristics @ T_J = 25°C (unless otherwise stated)							
Q_g	Gate Charge	$V_{CE}=520V, I_C=40A, V_{GE}=15V$	--	109.32	--	nC	
Q_{ge}	Gate to Emitter Charge		--	24.8	--	nC	
Q_{gc}	Gate to Collector Charge		--	38.08	--	nC	
C_{ies}	Input Capacitance	$V_{CE}=25V, V_{GE}=0V, f=1MHz$	--	3001	--	pF	
C_{oes}	Output Capacitance		--	72	--	pF	
C_{res}	Reverse Transfer Capacitance		--	11	--	pF	
$t_{d(on)}$	Turn-on Delay Time	$V_{CC}=400V, I_C=40A$ $R_{G(on)}=10\Omega, R_{G(off)}=1.0\Omega$ $V_{GE}=15V,$ Inductive Load	$T_J=25°C$	--	28	--	ns
			$T_J=150°C$	--	26	--	ns
t_r	Turn-on Rise Time		$T_J=25°C$	--	60	--	ns
			$T_J=150°C$	--	58	--	ns
$t_{d(off)}$	Turn-Off Delay Time		$T_J=25°C$	--	134	--	ns
			$T_J=150°C$	--	144	--	ns
t_f	Turn-Off Fall Time		$T_J=25°C$	--	60	--	ns
			$T_J=150°C$	--	74	--	ns
E_{on}	Turn on Energy		$T_J=25°C$	--	1.04	--	mJ
			$T_J=150°C$	--	1.12	--	mJ
E_{off}	Turn off Energy	$T_J=25°C$	--	0.73	--	mJ	
		$T_J=150°C$	--	0.94	--	mJ	

Diode, Inverter

Absolute Maximum Ratings (TC=25°C unless otherwise noted)						
Symbol	Parameter	Min	Typ	Max	Unit	
Common Ratings (TC=25°C Unless Otherwise Noted)						
V_F	Forward Voltage	$I_F=40A, V_{GE}=0V,$	$T_J=25°C$	--	1.62	V
			$T_J=150°C$	--	1.43	V
t_{rr}	Reverse Recovery Time	$I_F=40A, V_R=400V$ $dI_F/dt=400A/\mu s$	$T_J=25°C$	--	109.24	ns
			$T_J=150°C$	--	195.12	ns
I_{rrm}	Peak reverse recovery current		$T_J=25°C$	--	8.398	A
			$T_J=150°C$	--	23.308	A
Q_{rr}	Repetitive peak forward current		$T_J=25°C$	--	425.98	nC
			$T_J=150°C$	--	2366	nC

Typical Operating Characteristics

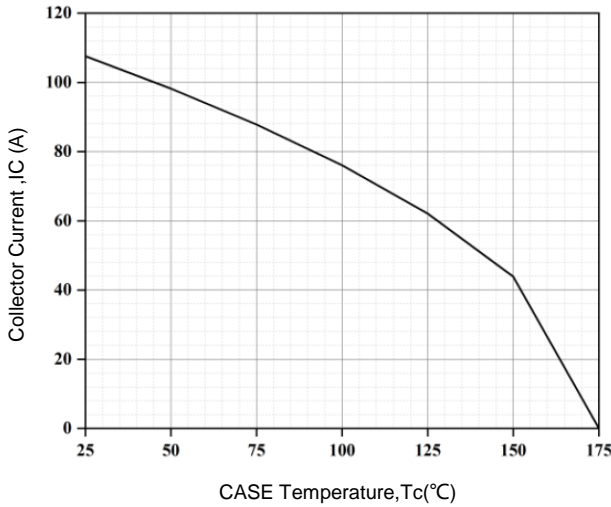

Figure 1. Collector current as a function of case temperature

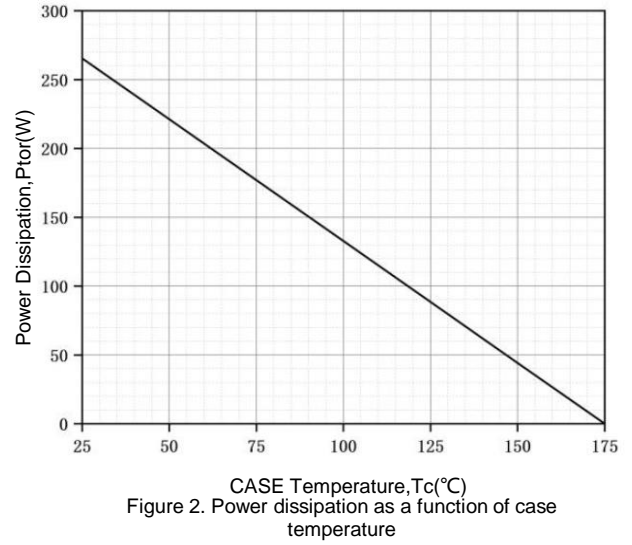

Figure 2. Power dissipation as a function of case temperature

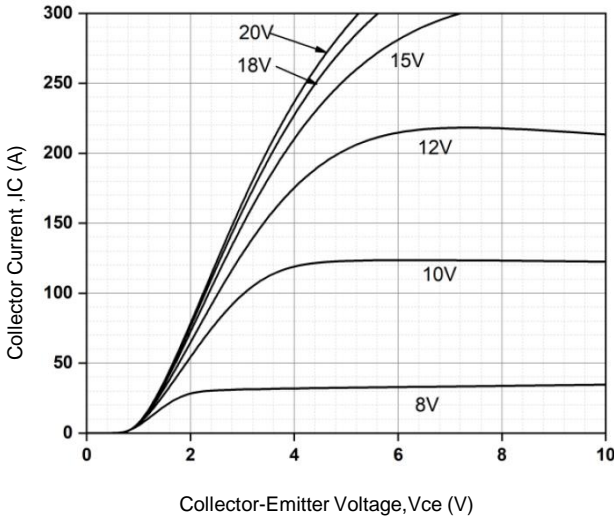

Figure 3. Typical output characteristic (Tj=25°C)

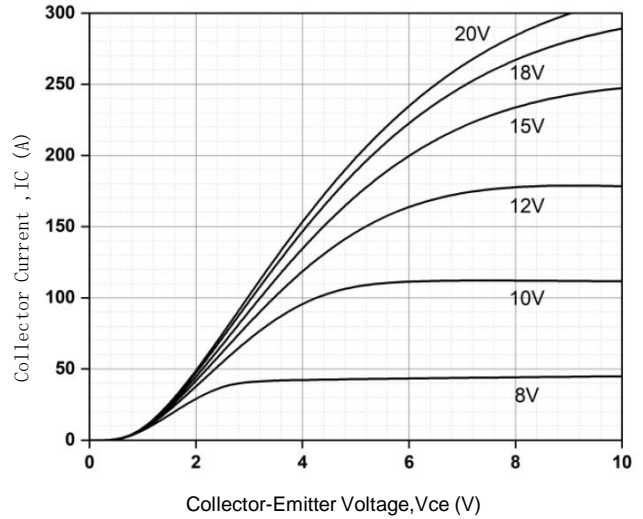

Figure 4. Typical output characteristic (Tj=150°C)

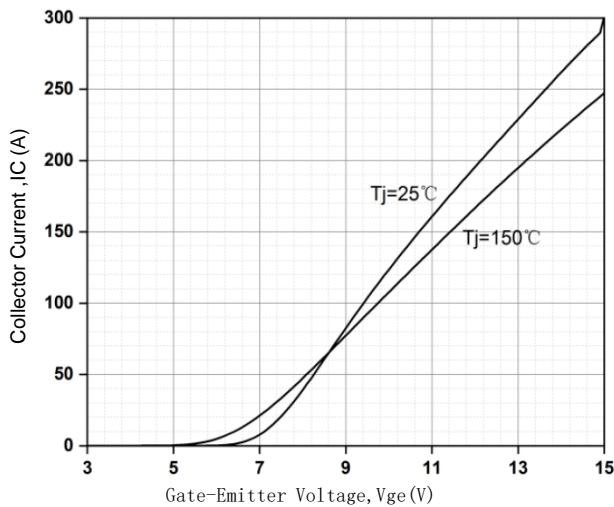

Figure 5. Typical transfer characteristic (Vce=20V)

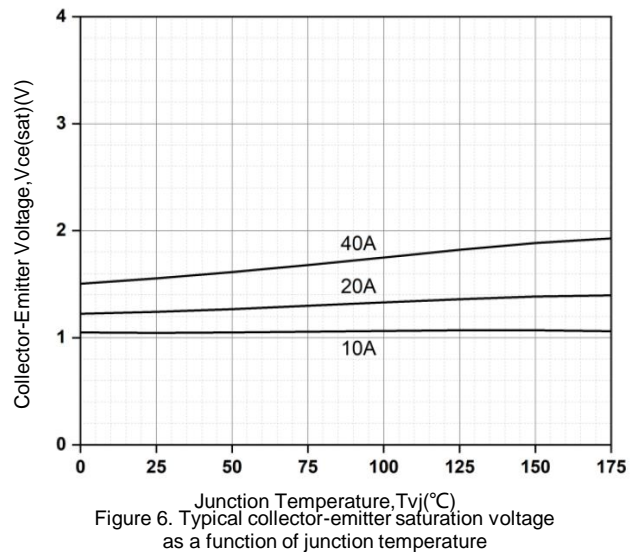

Figure 6. Typical collector-emitter saturation voltage as a function of junction temperature

Typical Operating Characteristics

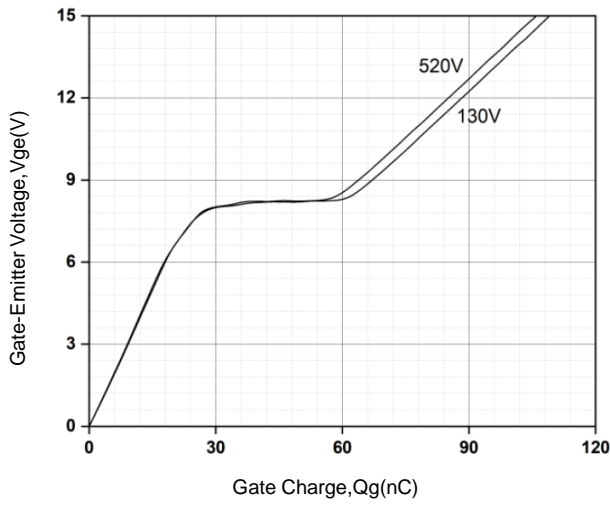

Figure 7. Typical gate charge

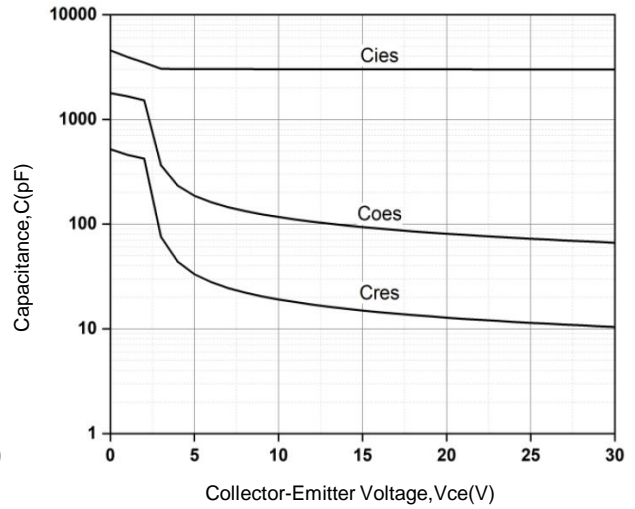

Figure 8. Typical capacitance as a function of collector-emitter voltage (f=1MHz)

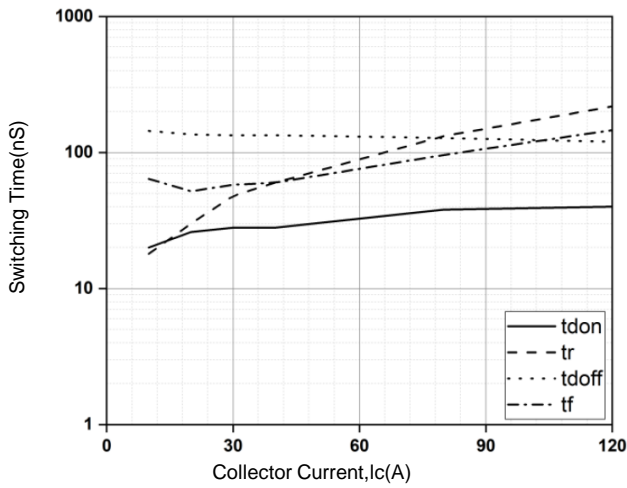

Figure 9. Typical switching times as a function of

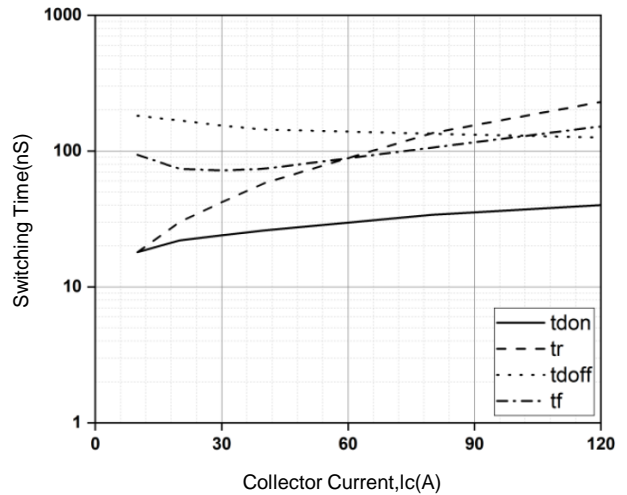

Figure 10. Typical switching times as a function of

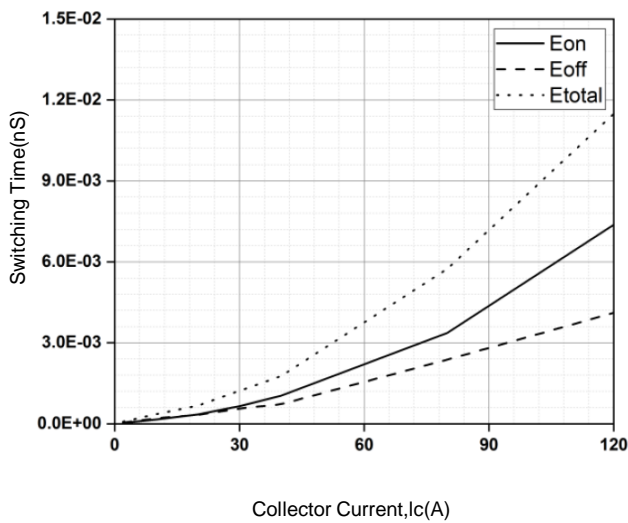

Figure 11. Typical switching energy losses as a function

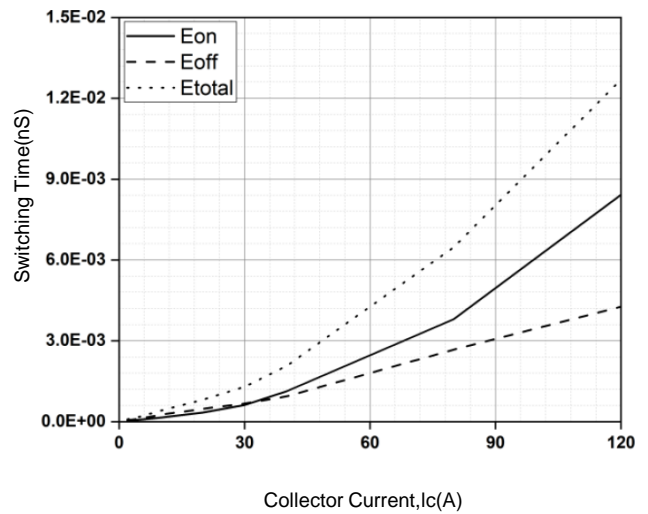

Figure 12. Typical switching energy losses as a function

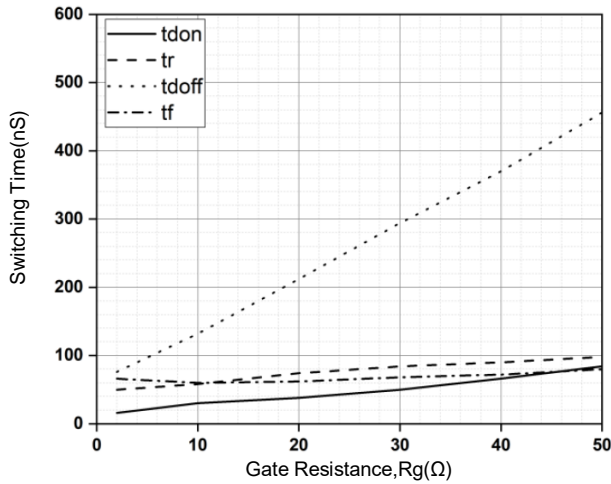

Figure 13. Typical switching times as a function of

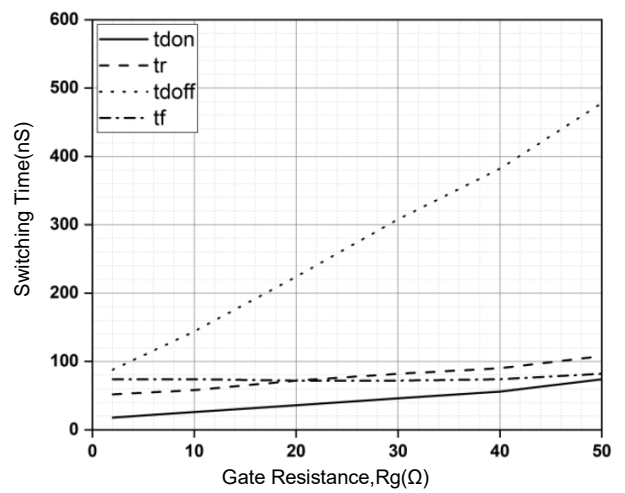

Figure 14. Typical switching times as a function of

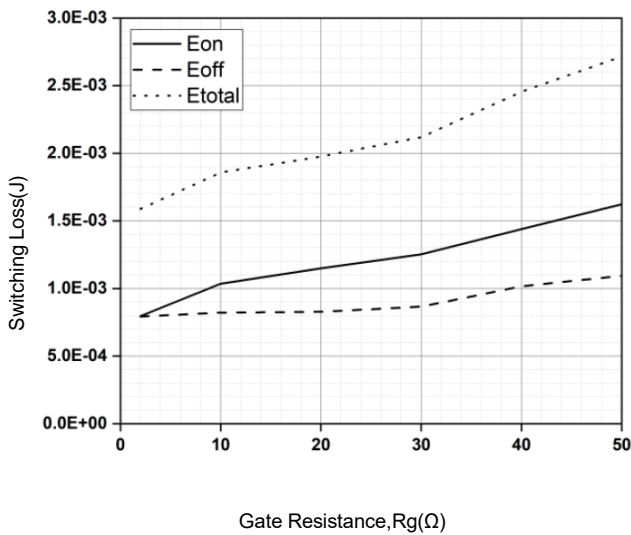

Figure 15. Typical switching energy losses as a function of

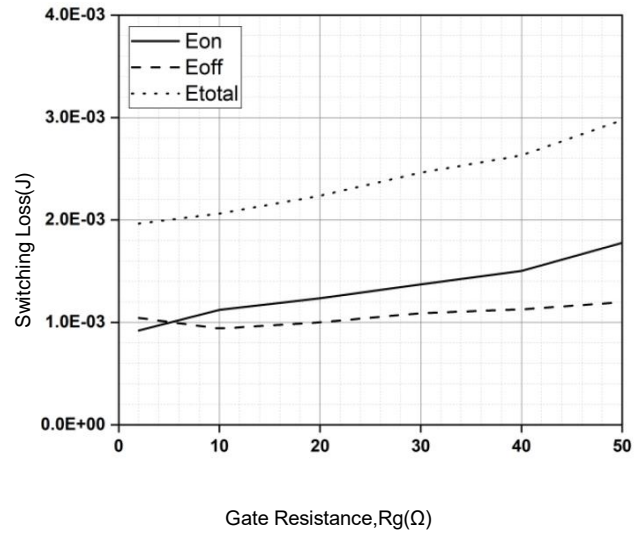

Figure 16. Typical switching energy losses as a function of

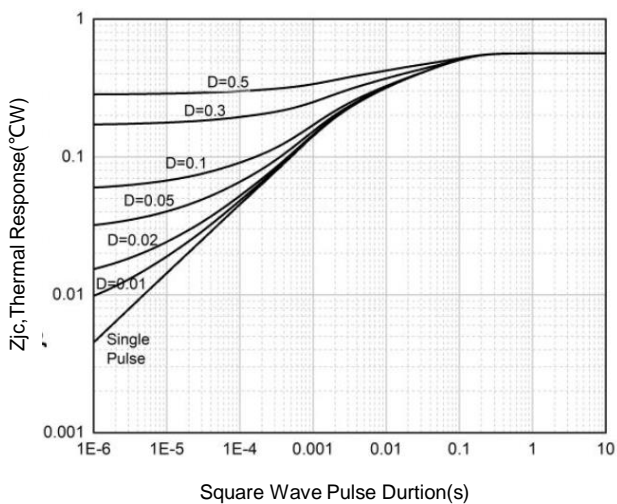

Figure 17. IGBT transient thermal impedance($D=tp/T$)

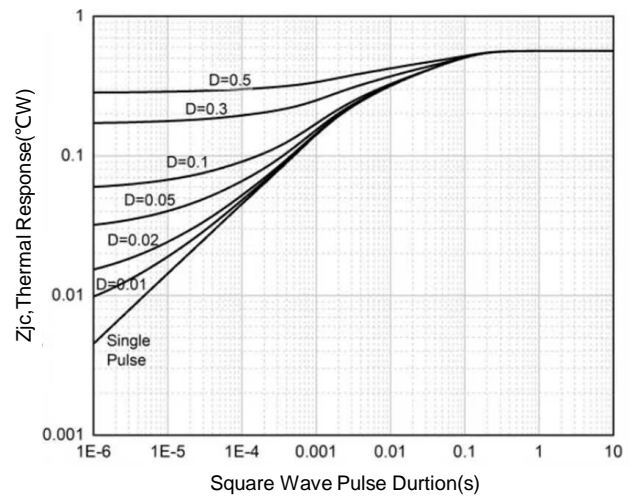

Figure 18. Diode transient thermal impedance as a function of pulse width($D=tp/T$)

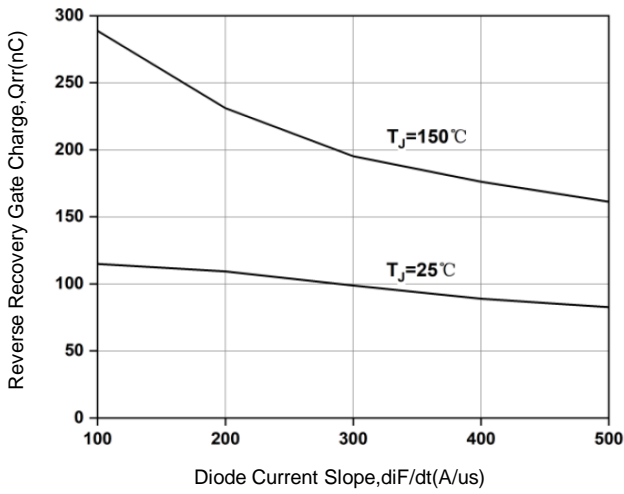

Figure 19. Typical reverse recovery charge as a function of diode current slope ($V_{CC}=400V$, $I_F=40A$)

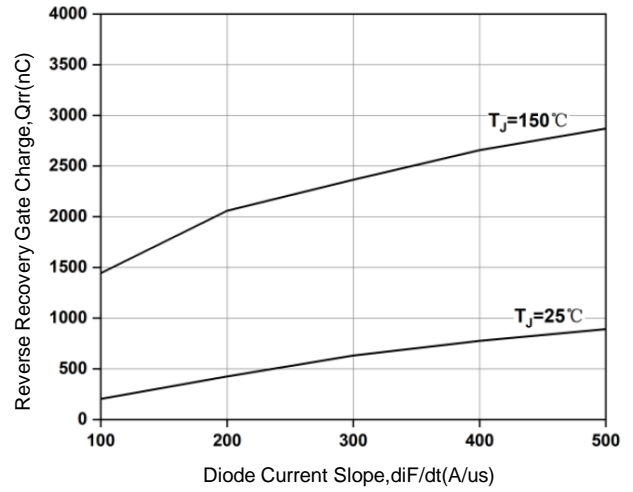

Figure 20. Typical reverse recovery time as a function of diode current slope ($V_{CC}=400V$, $I_F=40A$)

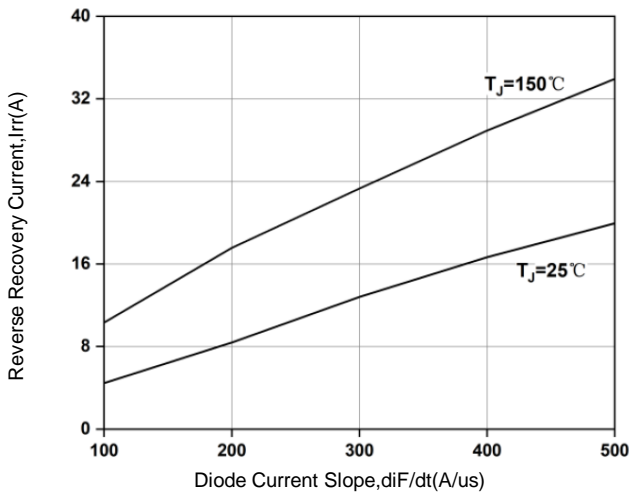

Figure 21. Typical reverse recovery current as a function of diode current slope ($V_{CC}=400V$, $I_F=40A$)

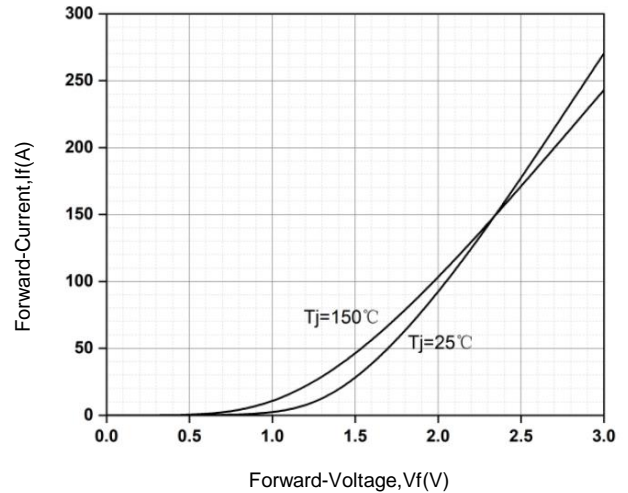

Figure 22. Typical diode forward current as a function of forward voltage

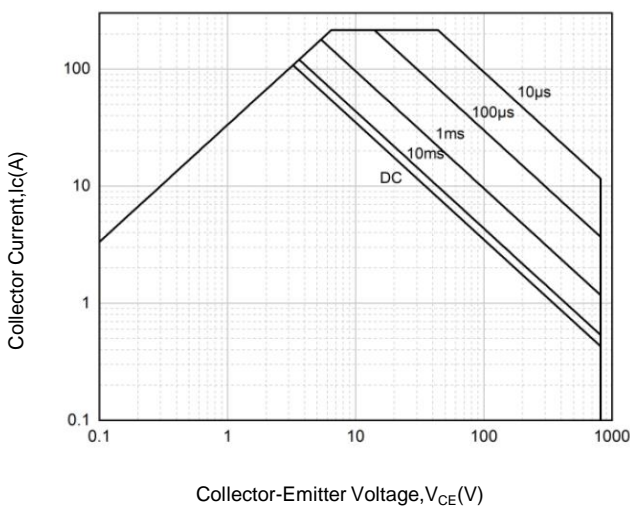
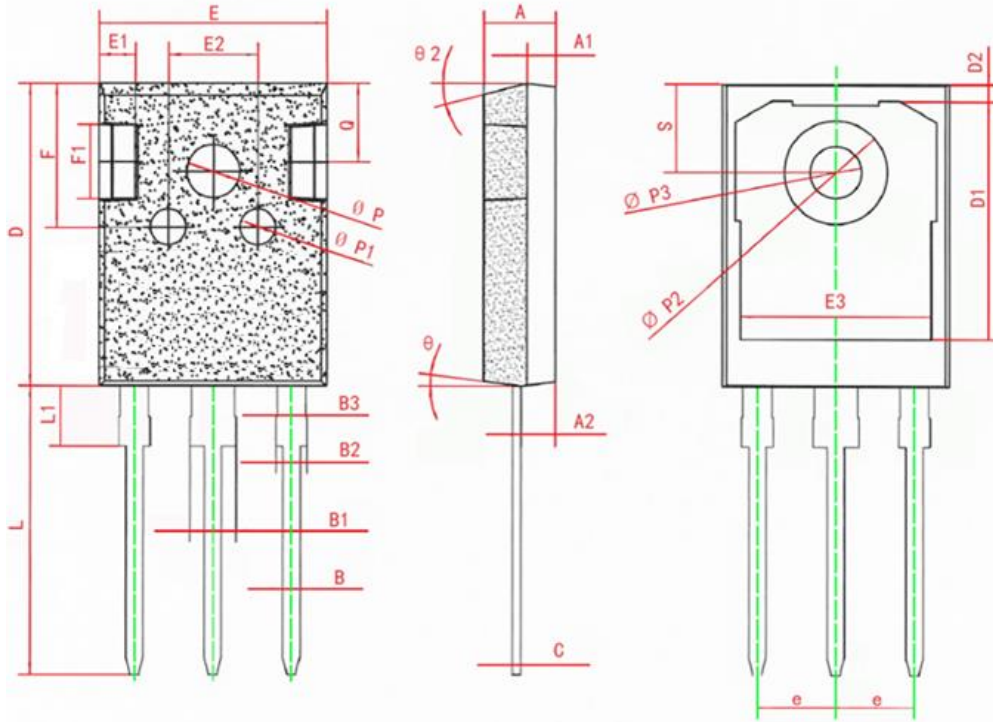

Figure 23. Safe operating area

TO-247 Package information

Symbol	Dimensions in Millimeters(mm)		Dimensions In Inches	
	Min	Max	Min	Max
A	4.900	5.100	0.192	0.200
A1	1.900	2.100	0.074	0.082
A2	2.300	2.500	0.090	0.098
B	1.140	1.240	0.044	0.048
B1	3.050	3.250	0.120	0.127
B2	2.000	2.200	0.078	0.086
B3	1.900	2.100	0.074	0.082
C	0.550	0.650	0.021	0.025
D	20.800	21.200	0.818	0.834
D1	16.350	16.750	0.643	0.659
D2	1.020	1.320	0.040	0.051
E	15.600	16.000	0.614	0.629
E1	2.400	2.600	0.094	0.102
E2	6.100	6.300	0.240	0.248
E3	13.060	13.460	0.514	0.529
F	9.800	10.200	0.385	0.401
F1	4.800	5.400	0.188	0.212
F2	7.900	8.100	0.311	0.318
e	5.436BSC		0.214BSC	
L	19.720	20.120	0.776	0.792
L1	3.900	4.300	0.153	0.169
ΦP	3.550	3.950	0.139	0.155
ΦP1	2.400	2.600	0.094	0.102
ΦP2	7.090	7.290	0.279	0.287
ΦP3	3.500	3.700	0.137	0.145
S	6.050	6.250	0.238	0.246
Q	5.400	5.600	0.212	0.220
θ	5°	9°	5°	9°
θ1	5°	9°	5°	9°
θ2	13°	17°	13°	17°