

### Features

- IGBT CHIP(Trench+Field Stop technology)
- Low Vcesat(typ) 1.5V@IC=50A
- Maximum junction temperature 175°C
- Low gate charge Qg
- RoHS compliant

### Application

- DC-AC inverters
- Motion/servo control
- UPS systems



G7E50M65FA : Device code  
 XXXXXXXX : Code

### Product Summary

V <sub>CE</sub>	I <sub>C</sub> (T <sub>J</sub> =100°C)	V <sub>CE(sat)</sub>
650V	50A	1.5V



TO-247 top view

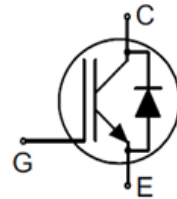

Schematic diagram



Halogen-Free

### Marking and pin assignment

Absolute Maximum Ratings (TC=25°C unless otherwise noted)				
Symbol	Parameter	Rating	Unit	
<b>Common Ratings (TC=25°C Unless Otherwise Noted)</b>				
IGBT, Inverter				
V <sub>CES</sub>	Collector Emitter Voltage	T <sub>J</sub> =25°C	650	V
V <sub>GES</sub>	Gate Emitter Voltage		±30	V
I <sub>C</sub>	DC Collector Current	T <sub>C</sub> =25°C	100	A
		T <sub>C</sub> =100°C	50	A
I <sub>CRM</sub>	Pulsed Collector Current, Limited by T <sub>vjmax</sub>	tp=1ms	200	A
P <sub>D</sub>	Power Dissipation	T <sub>C</sub> =25°C	364	W
		T <sub>C</sub> =100°C	182	W
Diode, Inverter				
V <sub>RRM</sub>	Repetitive Reverse Voltage	T <sub>J</sub> =25°C	650	V
I <sub>F</sub>	Forward current, DC	T <sub>C</sub> =25°C	100	A
		T <sub>J</sub> =100°C	50	A
T <sub>J</sub> , T <sub>stg</sub>	Operating Junction and Storage Temperature Range		-55 to +175	°C

### Ordering Information (Example)

Type	Package	Marking	Minimum Package(pcs)	Inner Box Quantity(pcs)	Outer Carton Quantity(pcs)
MGA50S65F7A	TO-247	G7E50M65FA	30	270	2,160

**IGBT, Inverter**

Electrical Characteristics (TC=25°C unless otherwise noted)							
Symbol	Parameter	Condition	Min	Typ	Max	Unit	
<b>Static Electrical Characteristics @ TC= 25°C (unless otherwise stated)</b>							
$V_{GE(th)}$	Gate Emitter Threshold Voltage	$V_{CE}=V_{GE}, I_C=0.25mA$	3.2	4.1	4.8	V	
$V_{CE(sat)}$	Collector - Emitter Saturation Voltage	$I_C=50A, V_{GE}=15V, T_J=25°C$	--	1.5	2	V	
		$I_C=50A, V_{GE}=15V, T_J=150°C$	--	1.8	--	V	
$I_{CES}$	Collector Leakage Current	$V_{CE}=650V, V_{GE}=0V, T_J=25°C$	--	--	500	nA	
$I_{GES}$	Gate Leakage Current	$V_{CE}=0V, V_{GE}=20V, T_J=25°C$	--	--	500	nA	
<b>Dynamic Electrical Characteristics @ T<sub>J</sub> = 25°C (unless otherwise stated)</b>							
$Q_g$	Gate Charge	$V_{CE}=520V, I_C=50A, V_{GE}=15V$	--	150	--	nC	
$Q_{ge}$	Gate to Emitter Charge		--	24	--	nC	
$Q_{gc}$	Gate to Collector Charge		--	55	--	nC	
$C_{ies}$	Input Capacitance	$V_{CE}=25V, V_{GE}=0V, f=1MHz$	--	3791	--	nF	
$C_{oes}$	Output Capacitance		--	135	--	nF	
$C_{res}$	Reverse Transfer Capacitance		--	11	--	pF	
$t_{d(on)}$	Turn-on Delay Time	$V_{CC}=400V, I_C=15A$ $R_{G(on)}=10\Omega, R_{G(off)}=1.0\Omega$ $V_{GE}=15V,$ Inductive Load	$T_J=25°C$	--	21	--	ns
			$T_J=150°C$	--	27	--	ns
$t_r$	Turn-on Rise Time		$T_J=25°C$	--	66	--	ns
			$T_J=150°C$	--	58	--	ns
$t_{d(off)}$	Turn-Off Delay Time		$T_J=25°C$	--	180	--	ns
			$T_J=150°C$	--	195	--	ns
$t_f$	Turn-Off Fall Time		$T_J=25°C$	--	48	--	ns
			$T_J=150°C$	--	48	--	ns
$E_{on}$	Turn on Energy		$T_J=25°C$	--	1.6	--	mJ
			$T_J=150°C$	--	2.2	--	mJ
$E_{off}$	Turn off Energy	$T_J=25°C$	--	0.7	--	mJ	
		$T_J=150°C$	--	0.77	--	mJ	

**Diode, Inverter**

Absolute Maximum Ratings (TC=25°C unless otherwise noted)							
Symbol	Parameter	Min	Typ	Max	Unit		
<b>Common Ratings (TC=25°C Unless Otherwise Noted)</b>							
$V_F$	Forward Voltage	$I_F=50A, V_{GE}=0V,$	$T_J=25°C$	--	1.6	--	V
			$T_J=150°C$	--	1.5	--	V
$t_{rr}$	Reverse Recovery Time	$I_F=50A, V_R=400V$ $dIF/dt=1000A/\mu s$	$T_J=25°C$	--	70.08	--	ns
			$T_J=150°C$	--	113	--	ns
$I_{rrm}$	Peak reverse recovery current		$T_J=25°C$	--	31.94	--	A
			$T_J=150°C$	--	51.55	--	A
$Q_{rr}$	Repetitive peak forward current		$T_J=25°C$	--	1350	--	nC
			$T_J=150°C$	--	3380	--	nC

**Typical Operating Characteristics**

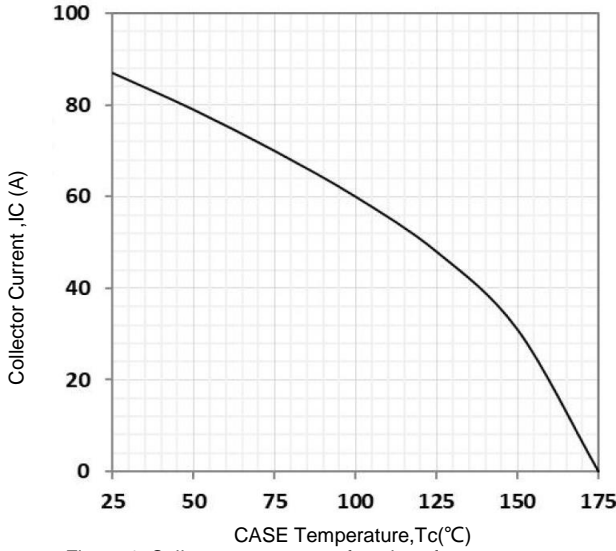

Figure 1. Collector current as a function of case temperature

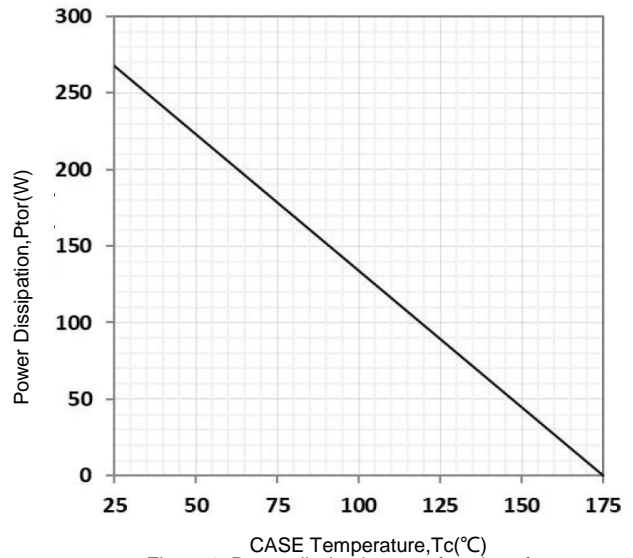

Figure 2. Power dissipation as a function of case temperature

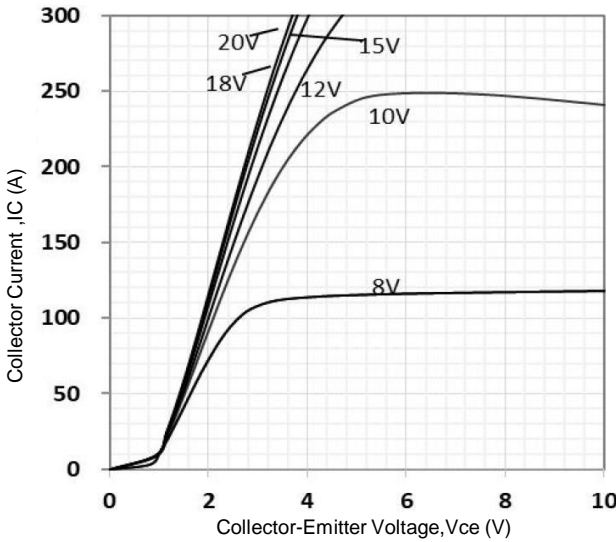

Figure 3. Typical output characteristic (Tj=25°C)

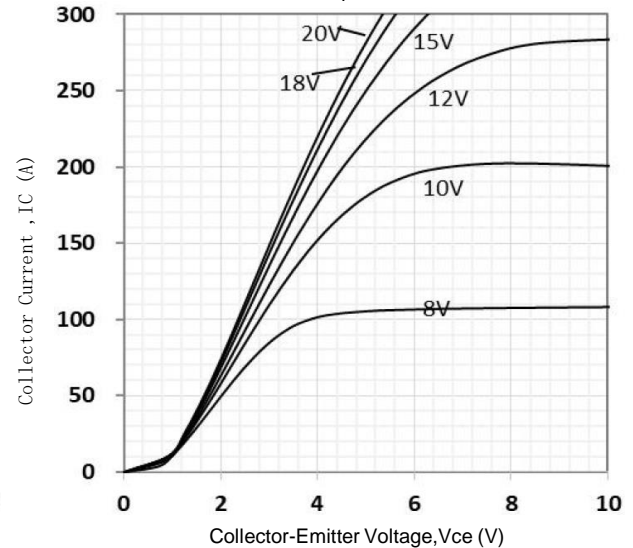

Figure 4. Typical output characteristic (Tj=150°C)

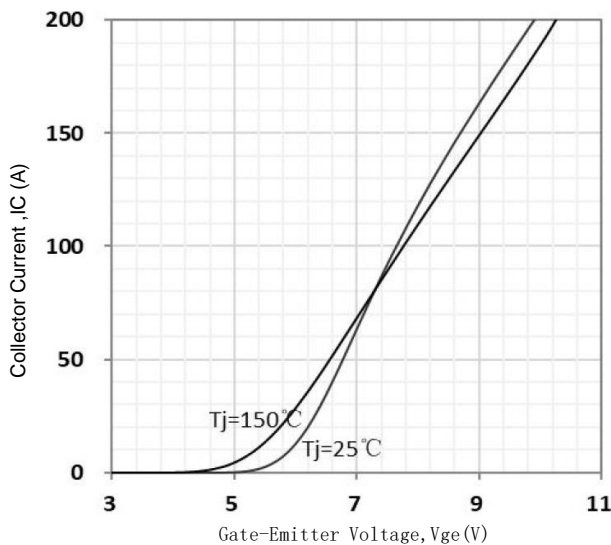

Figure 5. Typical transfer characteristic (Vce=20V)

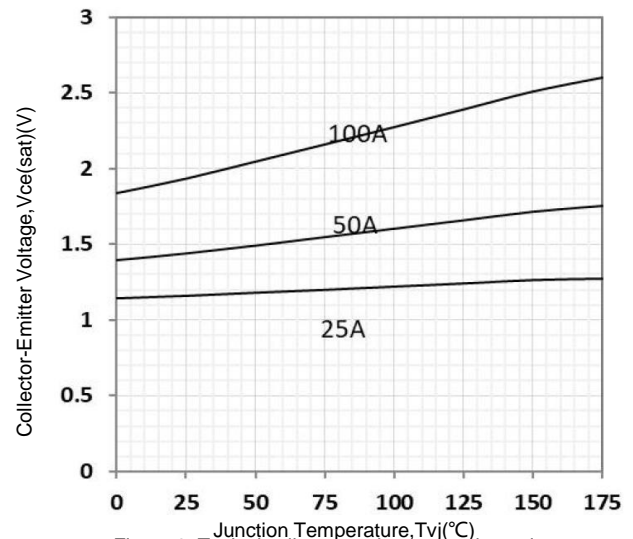

Figure 6. Typical collector-emitter saturation voltage as a function of junction temperature

**Typical Operating Characteristics**

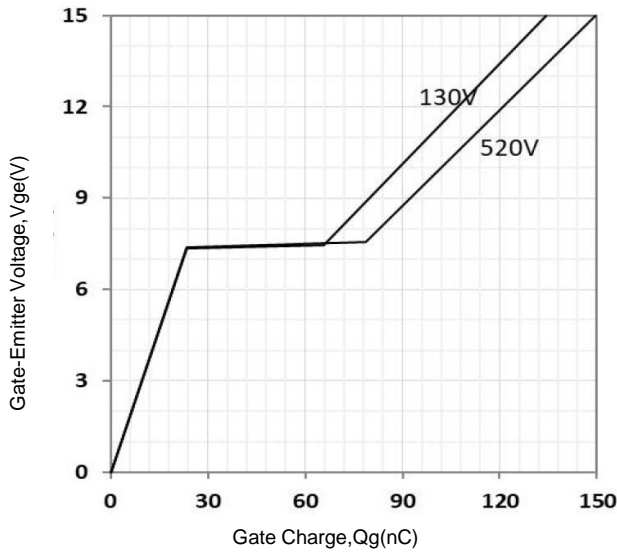

Figure 7. Typical gate charge

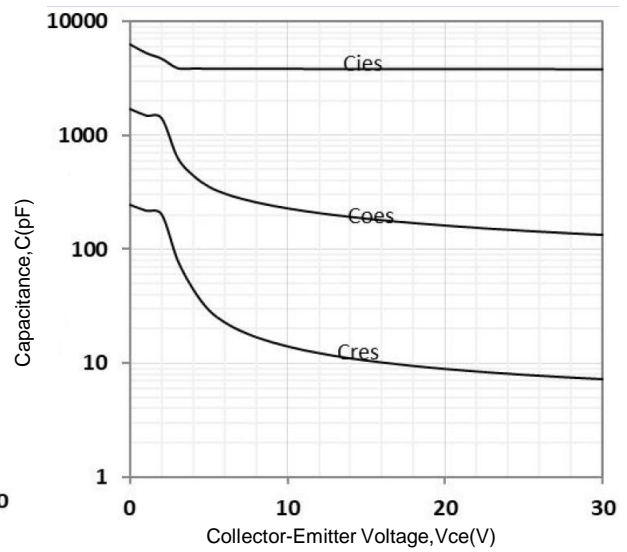

Figure 8. Typical capacitance as a function of collector-emitter voltage ( $f=1\text{MHz}$ )

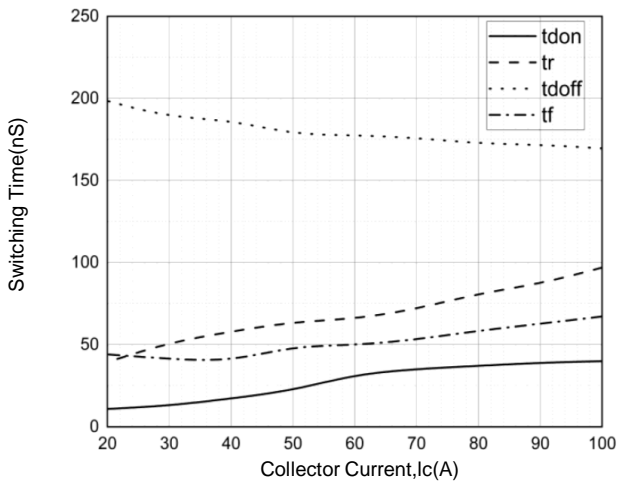

Figure 9. Typical switching times as a function of

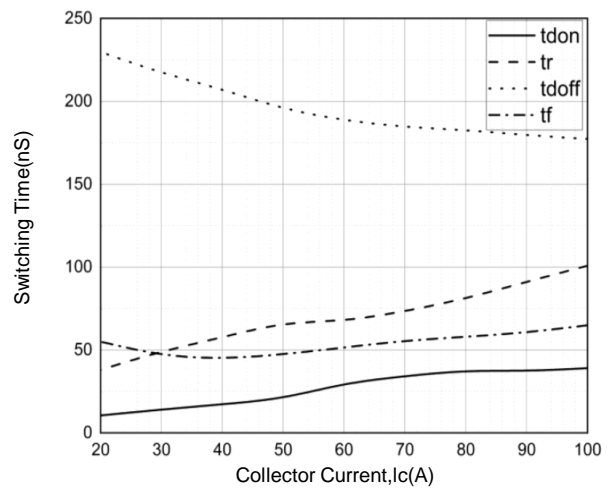

Figure 10. Typical switching times as a function of

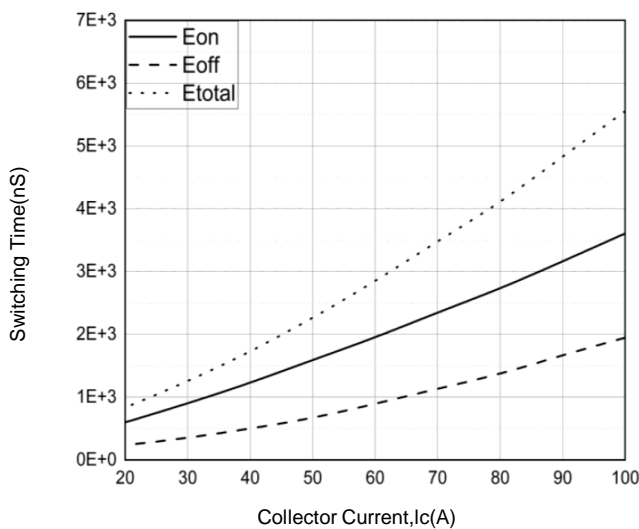

Figure 11. Typical switching energy losses as a function

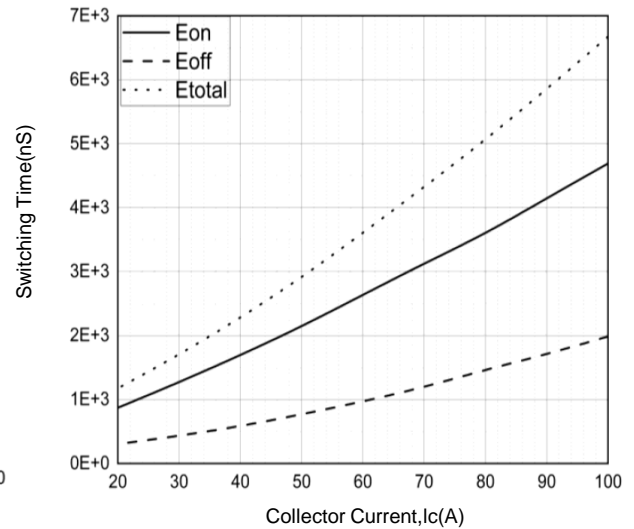

Figure 12. Typical switching energy losses as a function

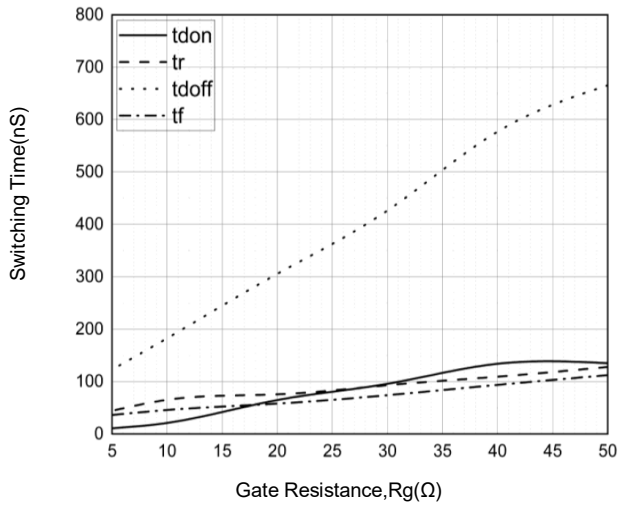

Figure 13. Typical switching times as a function of gate resistor ( $T_j=25^{\circ}\text{C}$ ,  $V_{CC}=400\text{V}$ ,  $I_c=50\text{A}$ )

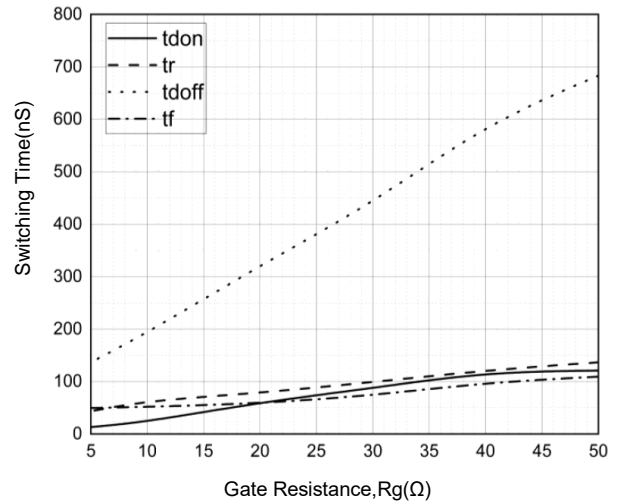

Figure 14. Typical switching times as a function of gate resistor ( $T_j=150^{\circ}\text{C}$ ,  $V_{CC}=400\text{V}$ ,  $I_c=50\text{A}$ )

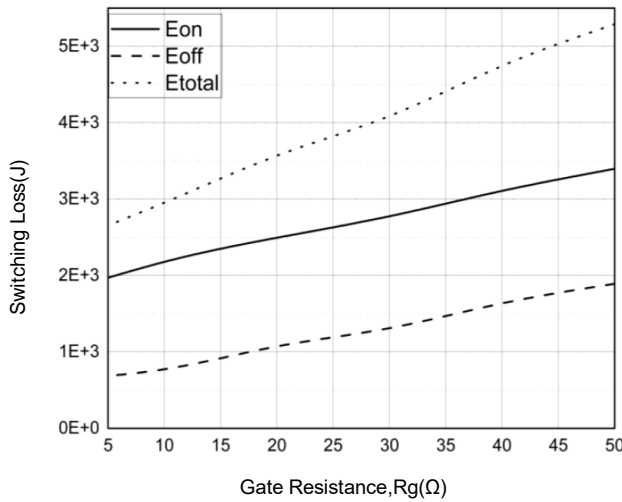

Figure 15. Typical switching energy losses as a function of

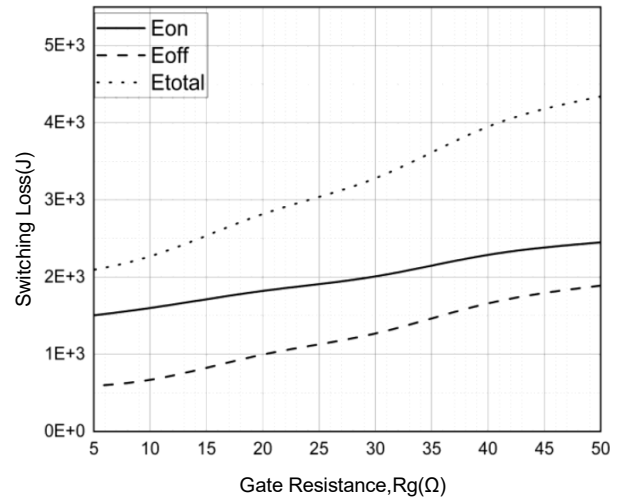

Figure 16. Typical switching energy losses as a function of

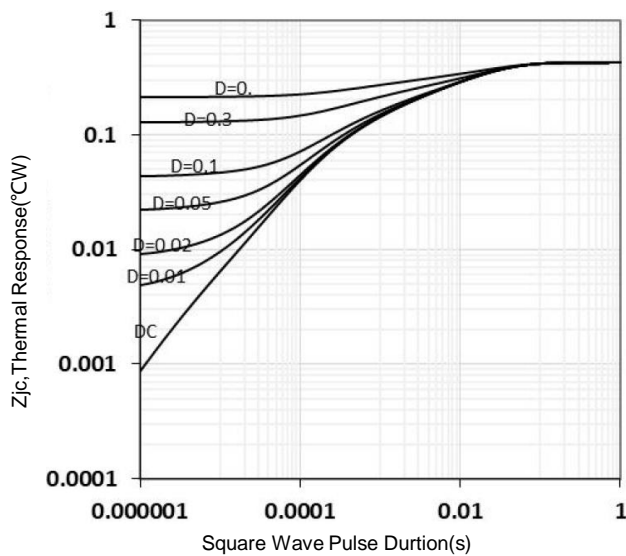

Figure 17. IGBT transient thermal impedance ( $D=tp/T$ )

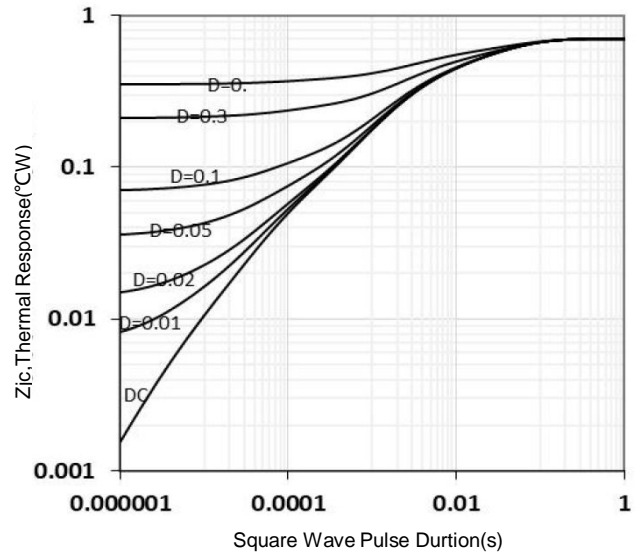
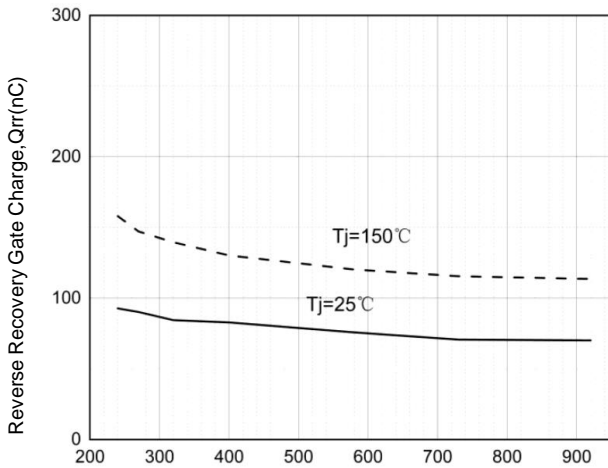
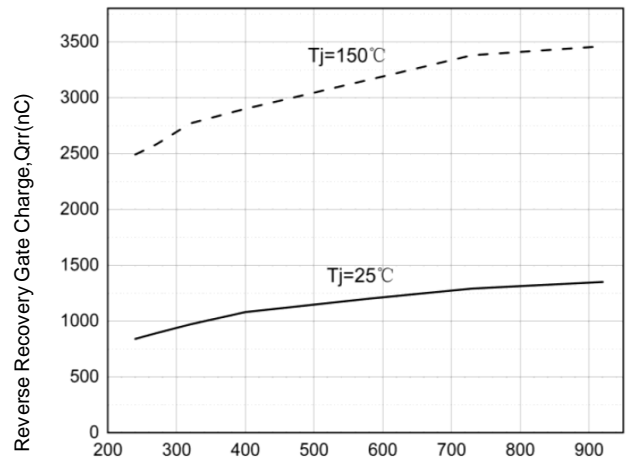

Figure 18. Diode transient thermal impedance as a function of pulse width ( $D=tp/T$ )



Diode Current Slope, diF/dt (A/us)

Figure 19. Typical reverse recovery charge as a function of diode current slope ( $V_{CC}=400V$ ,  $I_F=50A$ )



Diode Current Slope, diF/dt (A/us)

Figure 20. Typical reverse recovery time as a function of diode current slope ( $V_{CC}=400V$ ,  $I_F=50A$ )

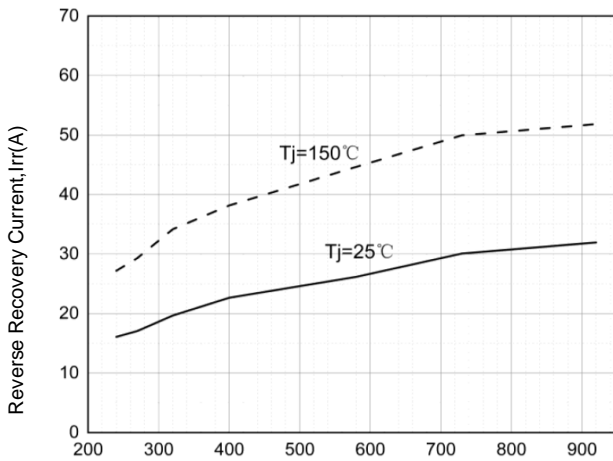

Diode Current Slope, diF/dt (A/us)

Figure 21. Typical reverse recovery current as a function of diode current slope ( $V_{CC}=400V$ ,  $I_F=50A$ )

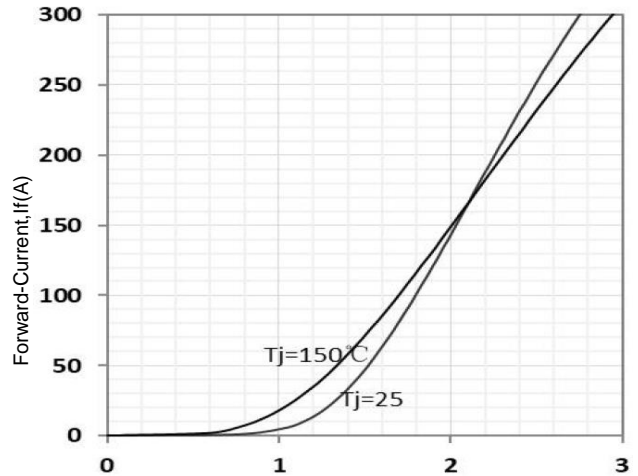

Forward Voltage, Vf (V)

Figure 22. Typical diode forward current as a function of forward voltage

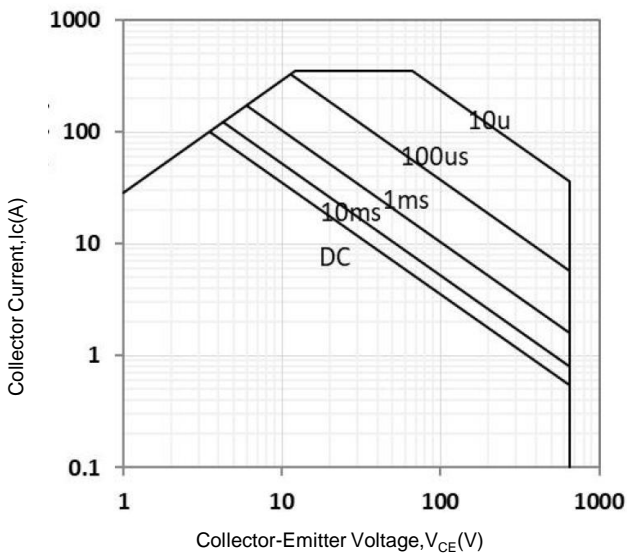
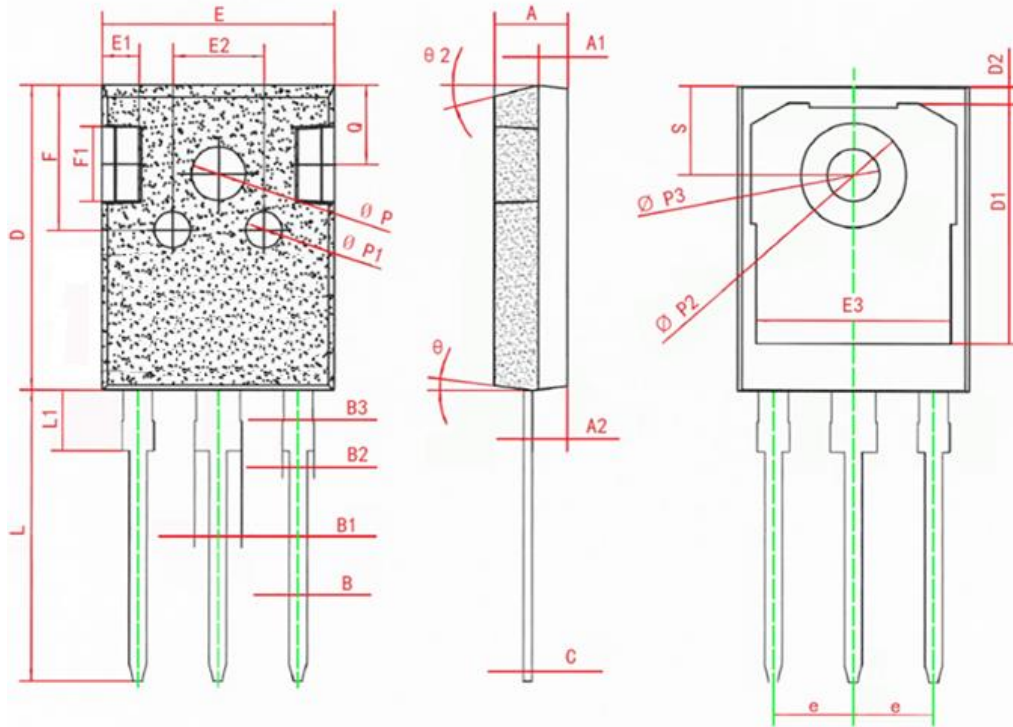

Figure 23. Safe operating area

**TO-247 Package information**

Symbol	Dimensions in Millimeters(mm)		Dimensions In Inches	
	Min	Max	Min	Max
A	4.900	5.100	0.192	0.200
A1	1.900	2.100	0.074	0.082
A2	2.300	2.500	0.090	0.098
B	1.140	1.240	0.044	0.048
B1	3.050	3.250	0.120	0.127
B2	2.000	2.200	0.078	0.086
B3	1.900	2.100	0.074	0.082
C	0.550	0.650	0.021	0.025
D	20.800	21.200	0.818	0.834
D1	16.350	16.750	0.643	0.659
D2	1.020	1.320	0.040	0.051
E	15.600	16.000	0.614	0.629
E1	2.400	2.600	0.094	0.102
E2	6.100	6.300	0.240	0.248
E3	13.060	13.460	0.514	0.529
F	9.800	10.200	0.385	0.401
F1	4.800	5.400	0.188	0.212
e	5.436BSC		0.214BSC	
L	19.720	20.120	0.776	0.792
L1	3.900	4.300	0.153	0.169
phi P	3.550	3.950	0.139	0.155
phi P1	2.400	2.600	0.094	0.102
phi P2	7.090	7.290	0.279	0.287
phi P3	3.500	3.700	0.137	0.145
S	6.050	6.250	0.238	0.246
Q	5.400	5.600	0.212	0.220
theta	5°	9°	5°	9°
theta1	5°	9°	5°	9°
theta2	13°	17°	13°	17°