

Features

- IGBT CHIP(Trench+Field Stop technology)
- Low Vcesat(typ) 1.5V@IC=15A
- Maximum junction temperature 175°C
- Short circuit withstand time 10us
- Low gate charge Qg

Application

- DC-AC inverters
- Motion/servo control
- UPS systems

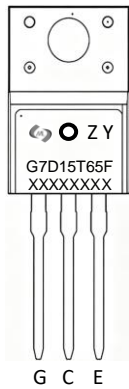

Marking and pin assignment

G7D15T65F : Device code
 XXXXXXXX : Code

Product Summary

V _{CE}	I _C (T _J =100°C)	V _{CE(sat)}
650V	15A	1.5V



TO-263 top view



TO-220F top view

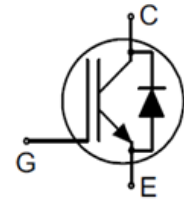

Schematic diagram



Pb-Free



RoHS



Halogen-Free

Absolute Maximum Ratings (TC=25°C unless otherwise noted)

Symbol	Parameter	Rating	Unit
--------	-----------	--------	------

Common Ratings (TC=25°C Unless Otherwise Noted)

IGBT, Inverter

V _{CES}	Collector Emitter Voltage	T _J =25°C	650	V
V _{GES}	Gate Emitter Voltage		±30	V
I _C	DC Collector Current	T _C =100°C	15	A
I _{CRM}	Repetitive peak collector current	t _p =1ms	64	A
t _{SC}	Short circuit withstand time	Short Circuit Withstand Time V _{GE} =15V, V _{CC} ≤ 360V, T _{vj} =150°C	10	μs
P _{tot}	Power Dissipation	T _C =25°C	78	W
		T _C =100°C	39	W

Diode, Inverter

V _{RRM}	Repetitive Reverse Voltage	T _J =25°C	650	V
I _F	Forward current, DC	T _J =100°C	15	A
I _{FRM}	Repetitive peak forward current	t _p =1ms	64	A

Ordering Information (Example)

Type	Package	Marking	Minimum Package(pcs)	Inner Box Quantity(pcs)	Outer Carton Quantity(pcs)	Delivery Mode
MGB15T65F7	TO-263	G7B15T65F	800	800	5,600	13" reel
MGYF15T65F7	TO-220F	G7D15T65F	50	1,000	5,000	Tube

IGBT, Inverter

Electrical Characteristics (TC=25°C unless otherwise noted)							
Symbol	Parameter	Condition	Min	Typ	Max	Unit	
Static Electrical Characteristics @ TC= 25°C (unless otherwise stated)							
$V_{GE(th)}$	Gate Emitter Threshold Voltage	$V_{CE}=V_{GE}, I_C=0.25mA$	4.5	5.3	6.0	V	
$V_{CE(sat)}$	Collector - Emitter Saturation Voltage	$I_C=15A, V_{GE}=15V, T_J=25^\circ C$	--	1.5	2	V	
		$I_C=15A, V_{GE}=15V, T_J=150^\circ C$	--	1.8	--	V	
I_{CES}	Collector Leakage Current	$V_{CE}=650V, V_{GE}=0V, T_J=25^\circ C$	--	--	200	nA	
I_{GES}	Gate Leakage Current	$V_{CE}=0V, V_{GE}=20V, T_J=25^\circ C$	--	--	200	nA	
Dynamic Electrical Characteristics @ T_J = 25°C (unless otherwise stated)							
Q_g	Gate Charge	$V_{CE}=520V, I_C=15A, V_{GE}=0 \text{ to } 15V$	--	40.8	--	nC	
Q_{ge}	Gate to Emitter Charge		--	11.5	--	nC	
Q_{gc}	Gate to Collector Charge		--	15	--	nC	
C_{ies}	Input Capacitance	$V_{CE}=25V, V_{GE}=0V, f=1MHz$	--	1123	--	nF	
C_{oes}	Output Capacitance		--	44	--	nF	
C_{res}	Reverse Transfer Capacitance		--	4	--	pF	
$t_{d(on)}$	Turn-on Delay Time	$V_{CC}=400V, I_C=15A$ $R_{G(on)}=10\Omega, R_{G(off)}=10\Omega$ $V_{GE}=15V,$ Inductive Load	$T_J=25^\circ C$	--	8	--	ns
			$T_J=150^\circ C$	--	8	--	ns
t_r	Turn-on Rise Time		$T_J=25^\circ C$	--	24	--	ns
			$T_J=150^\circ C$	--	24	--	ns
$t_{d(off)}$	Turn-Off Delay Time		$T_J=25^\circ C$	--	66	--	ns
			$T_J=150^\circ C$	--	88	--	ns
t_f	Turn-Off Fall Time		$T_J=25^\circ C$	--	76	--	ns
			$T_J=150^\circ C$	--	118	--	ns
E_{on}	Turn on Energy		$T_J=25^\circ C$	--	0.21	--	mJ
			$T_J=150^\circ C$	--	0.24	--	mJ
E_{off}	Turn off Energy		$T_J=25^\circ C$	--	0.31	--	mJ
			$T_J=150^\circ C$	--	0.43	--	mJ

Diode, Inverter

Absolute Maximum Ratings (TC=25°C unless otherwise noted)							
Symbol	Parameter	Min	Typ	Max	Unit		
Common Ratings (TC=25°C Unless Otherwise Noted)							
V_F	Forward Voltage	$I_F=15A, V_{GE}=0V,$	$T_J=25^\circ C$	--	1.6	2.2	V
			$T_J=150^\circ C$	--	1.4	--	V
t_{rr}	Reverse Recovery Time	$I_F=15A, V_R=400V$ $dI_F/dt=-200A/\mu s$	$T_J=25^\circ C$	--	45	--	ns
			$T_J=150^\circ C$	--	92	--	ns
I_{rrm}	Peak reverse recovery current		$T_J=25^\circ C$	--	6.2	--	A
			$T_J=150^\circ C$	--	10	--	A
Q_{rr}	Repetitive peak forward current		$T_J=25^\circ C$	--	141.5	--	μC
			$T_J=150^\circ C$	--	475.5	--	μC

Typical Operating Characteristics

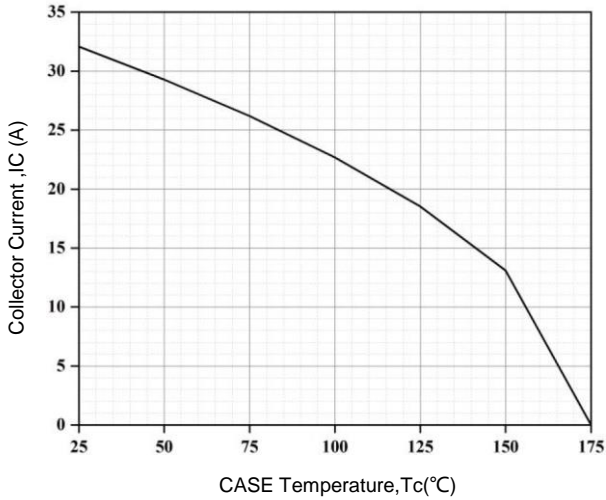

Figure 1. Collector current as a function of case temperature

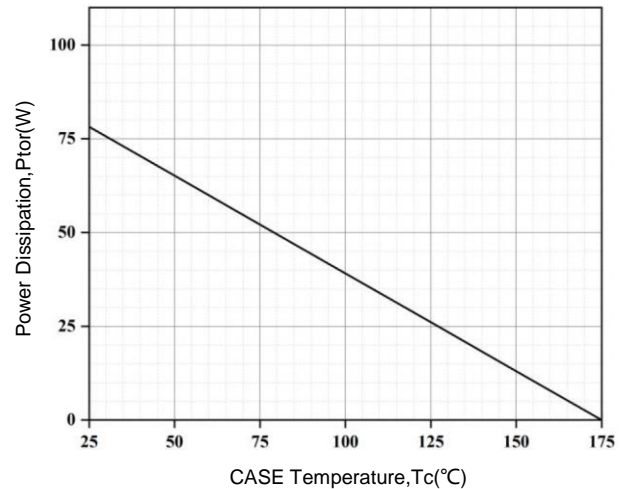

Figure 2. Power dissipation as a function of case temperature

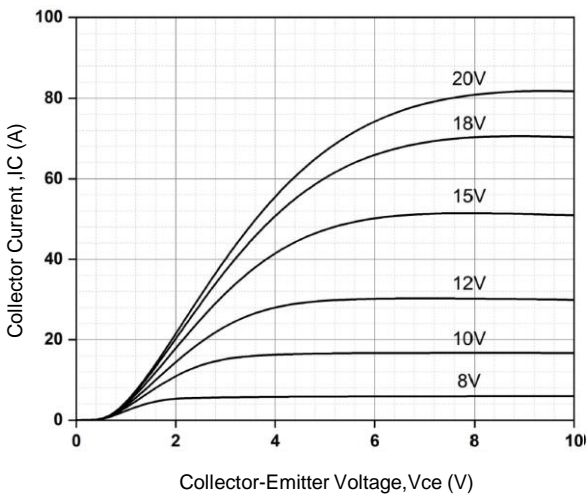

Figure 3. Typical output characteristic (Tj=25°C)

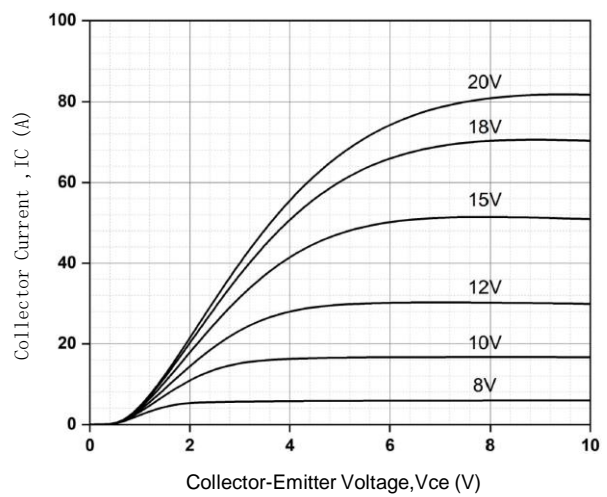

Figure 4. Typical output characteristic (Tj=150°C)

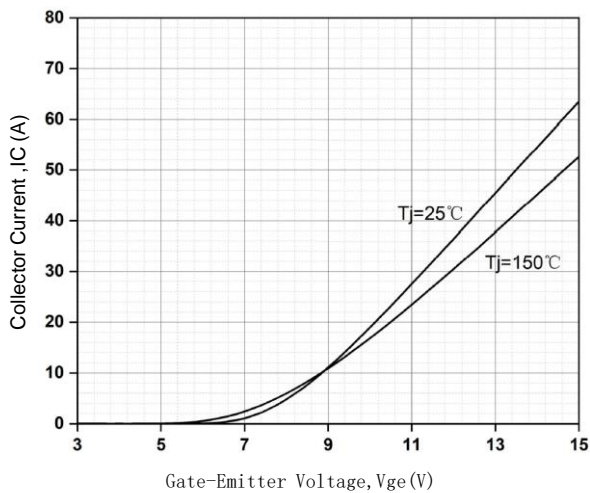

Figure 5. Typical transfer characteristic (Vce=10V)

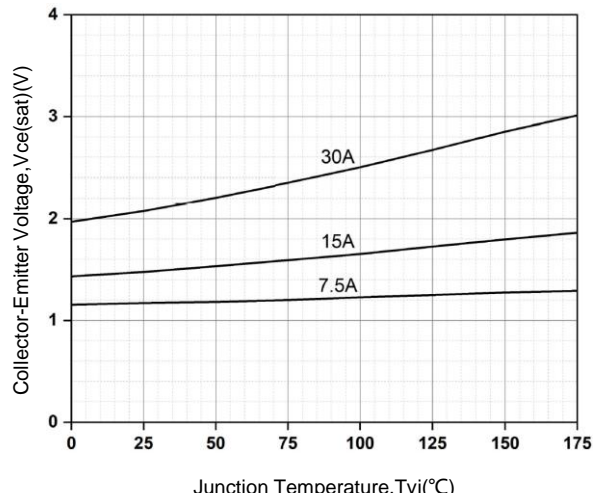

Figure 6. Typical collector-emitter saturation voltage as a function of junction temperature

Typical Operating Characteristics

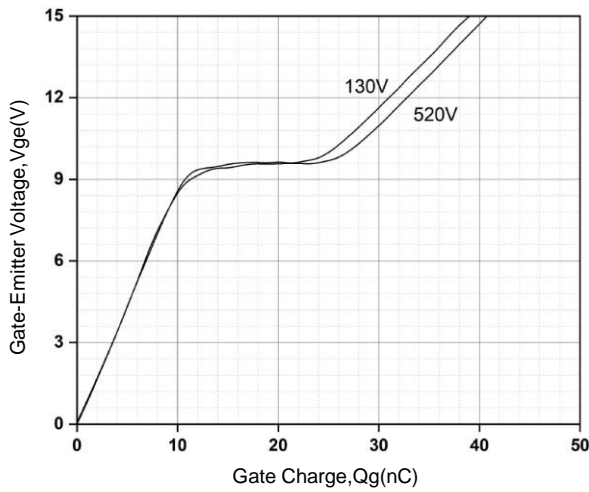

Figure 7. Typical gate charge

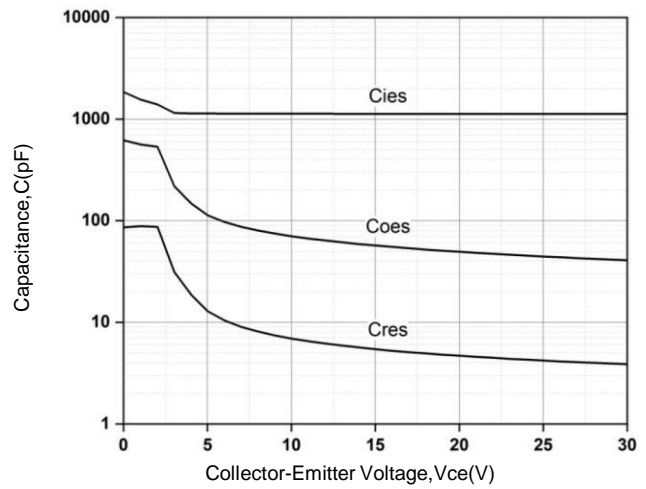

Figure 8. Typical capacitance as a function of collector-emitter voltage ($f=1\text{MHz}$)

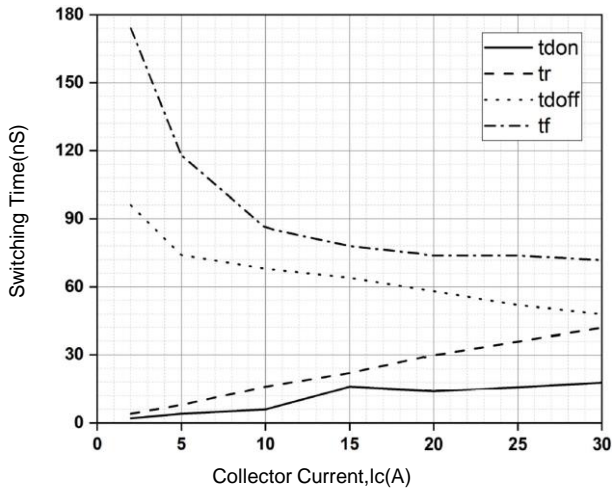

Figure 9. Typical switching times as a function of

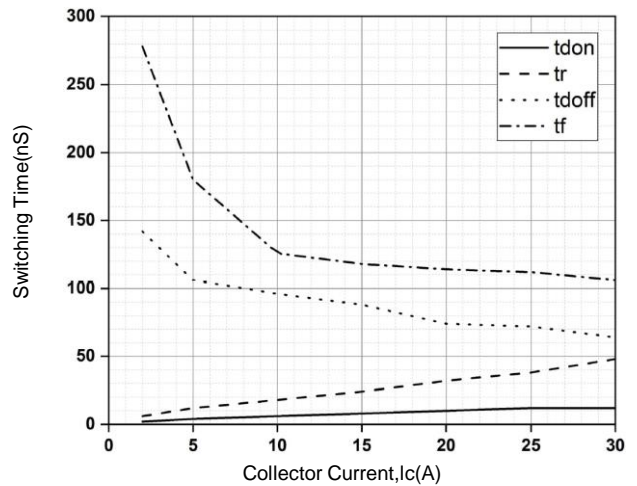

Figure 10. Typical switching times as a function of

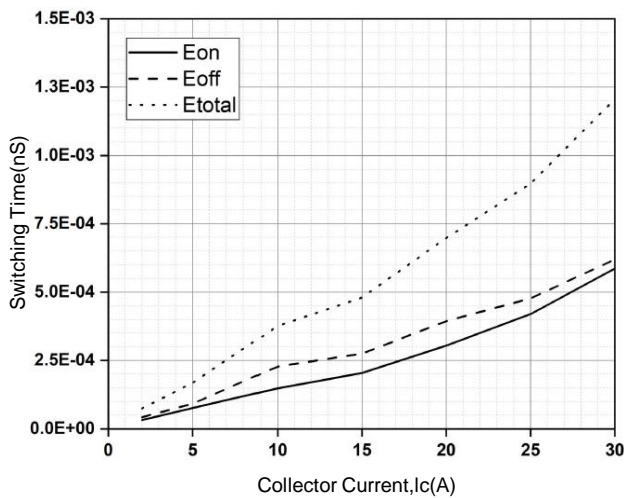

Figure 11. Typical switching energy losses as a function of collector current ($T_j=25^\circ\text{C}$, $V_{CC}=400\text{V}$, $R_g=10\Omega$)

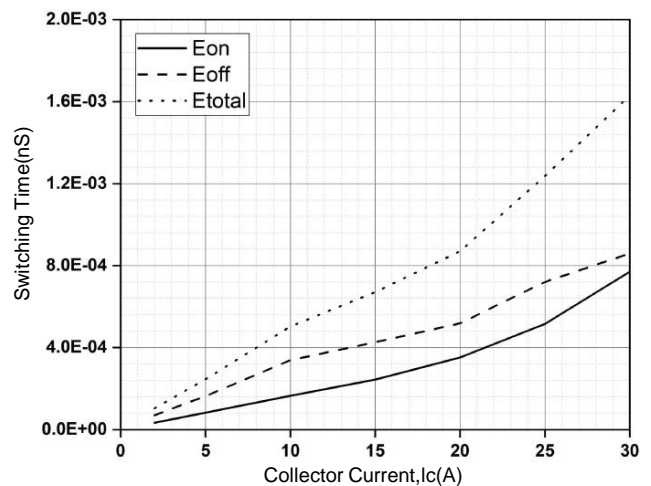

Figure 12. Typical switching energy losses as a function of collector current ($T_j=150^\circ\text{C}$, $V_{CC}=400\text{V}$, $R_g=10\Omega$)

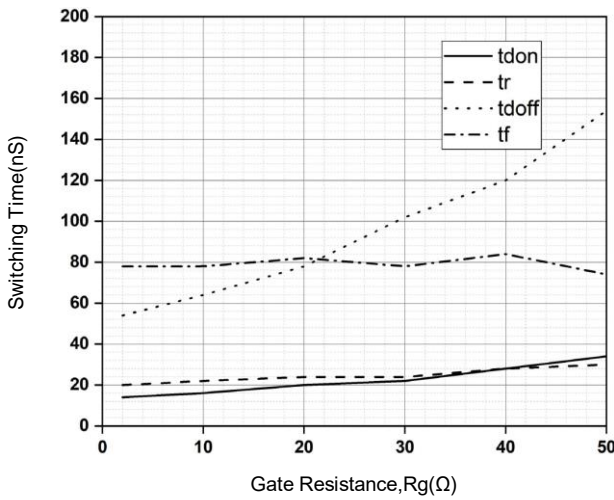

Figure 13. Typical switching times as a function of

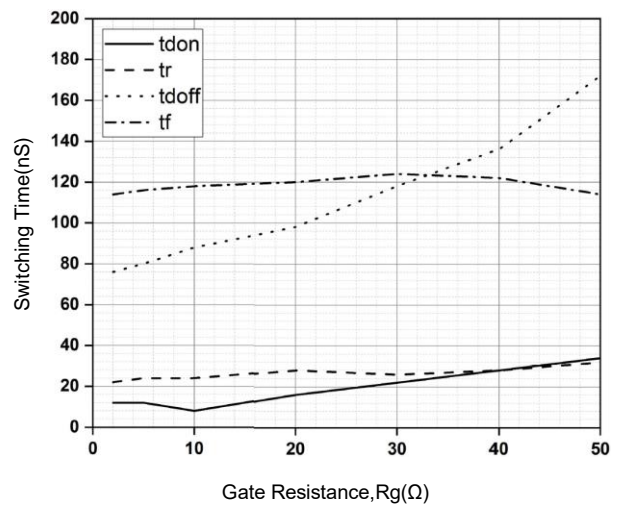

Figure 14. Typical switching times as a function of

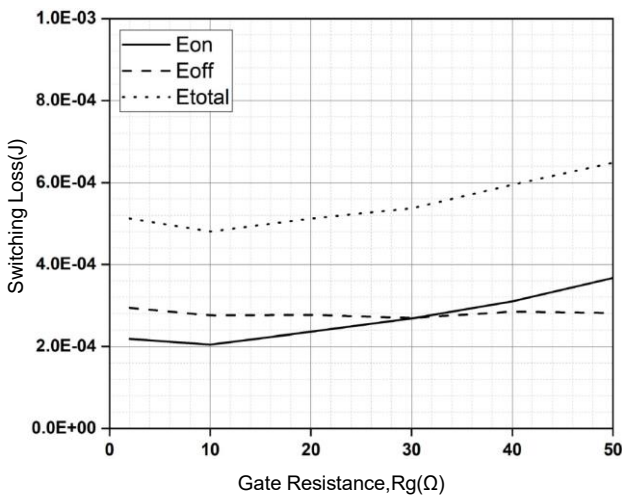

Figure 16. Typical switching energy losses as a function of

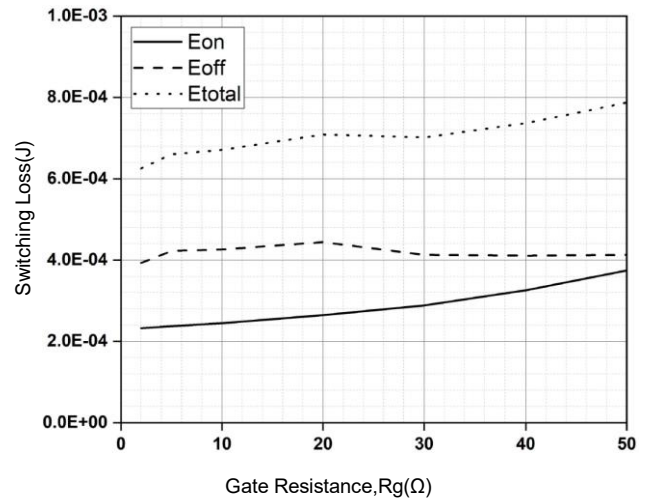

Figure 16. Typical switching energy losses as a function of

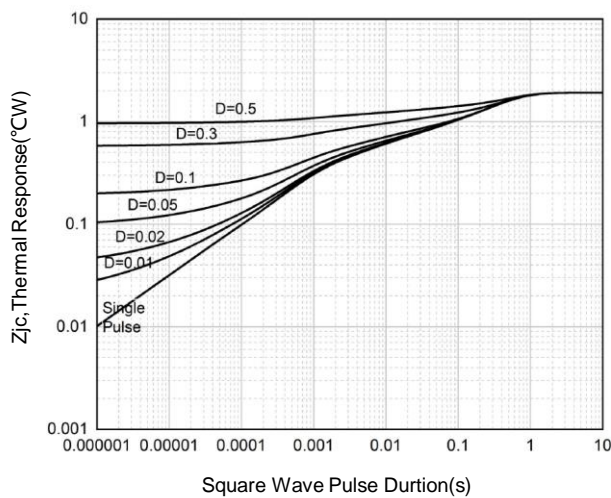

Figure 17. IGBT transient thermal impedance($D=tp/T$)

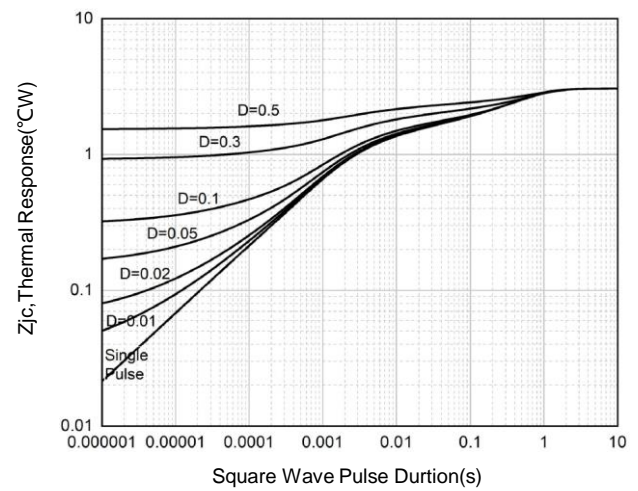

Figure 18. Diode transient thermal impedance as a function of pulse width($D=tp/T$)

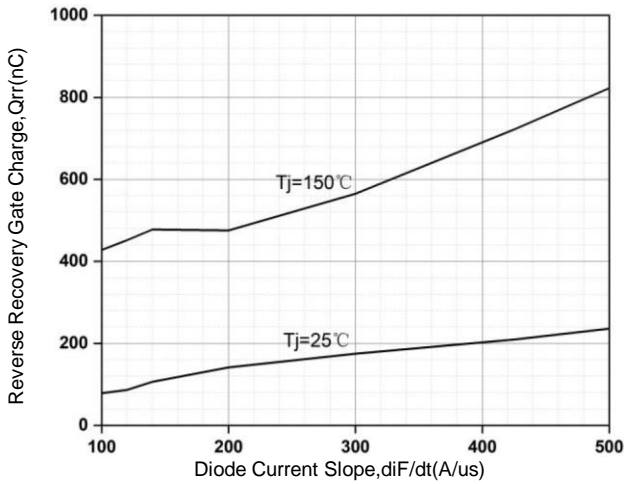

Figure 19. Typical reverse recovery charge as a function of diode current slope ($V_{CC}=400V$, $I_F=15A$)

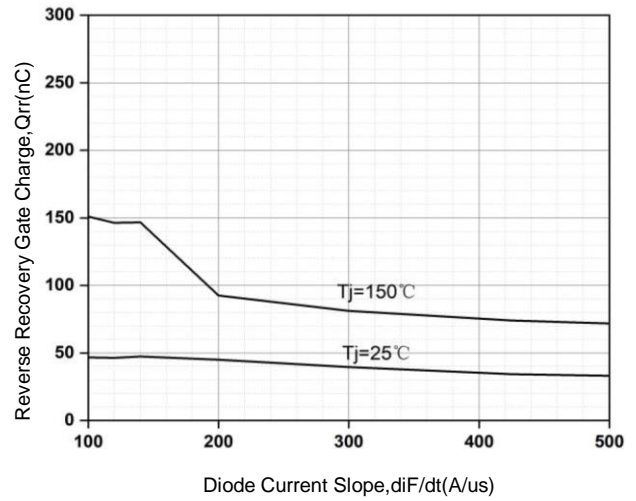

Figure 20. Typical reverse recovery time as a function of diode current slope ($V_{CC}=400V$, $I_F=15A$)

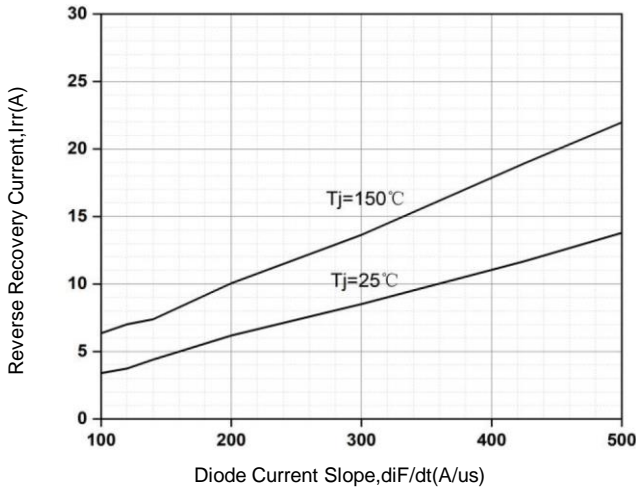

Figure 21. Typical reverse recovery current as a function of diode current slope ($V_{CC}=400V$, $I_F=15A$)

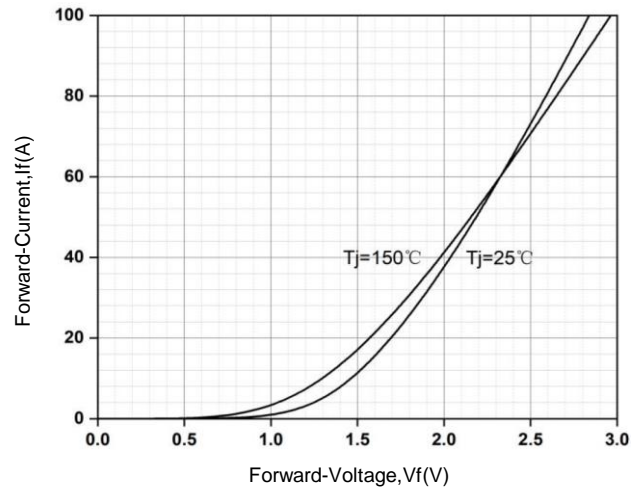

Figure 22. Typical diode forward current as a function of forward voltage

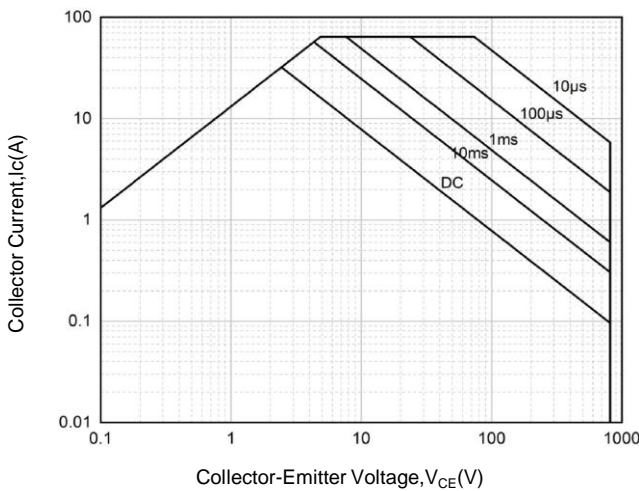
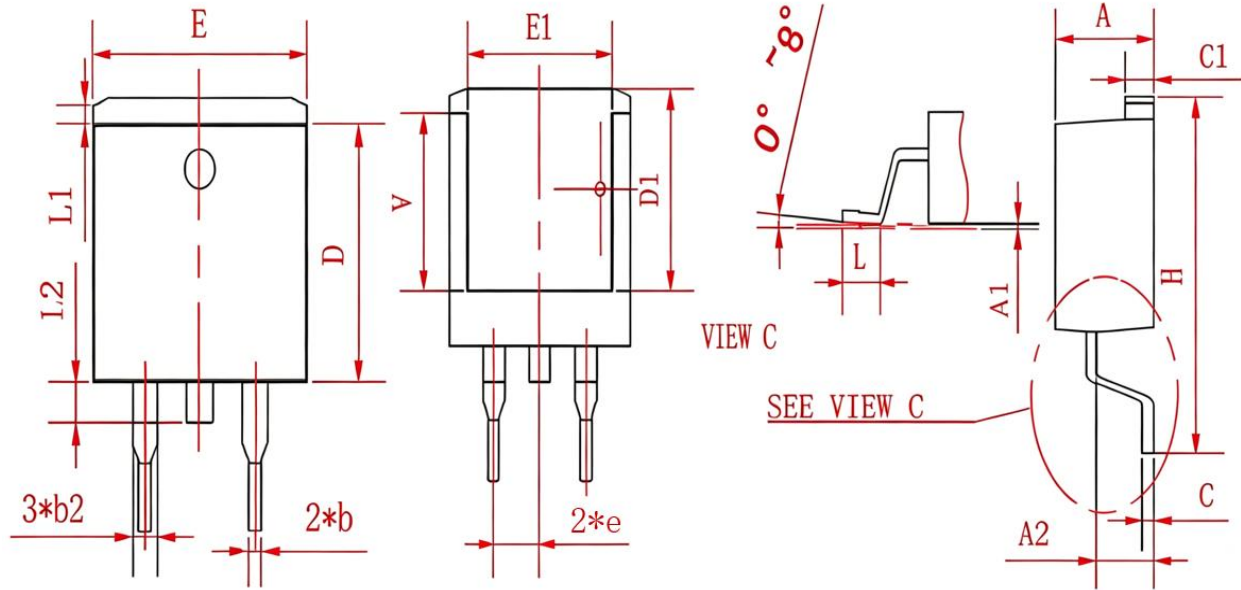
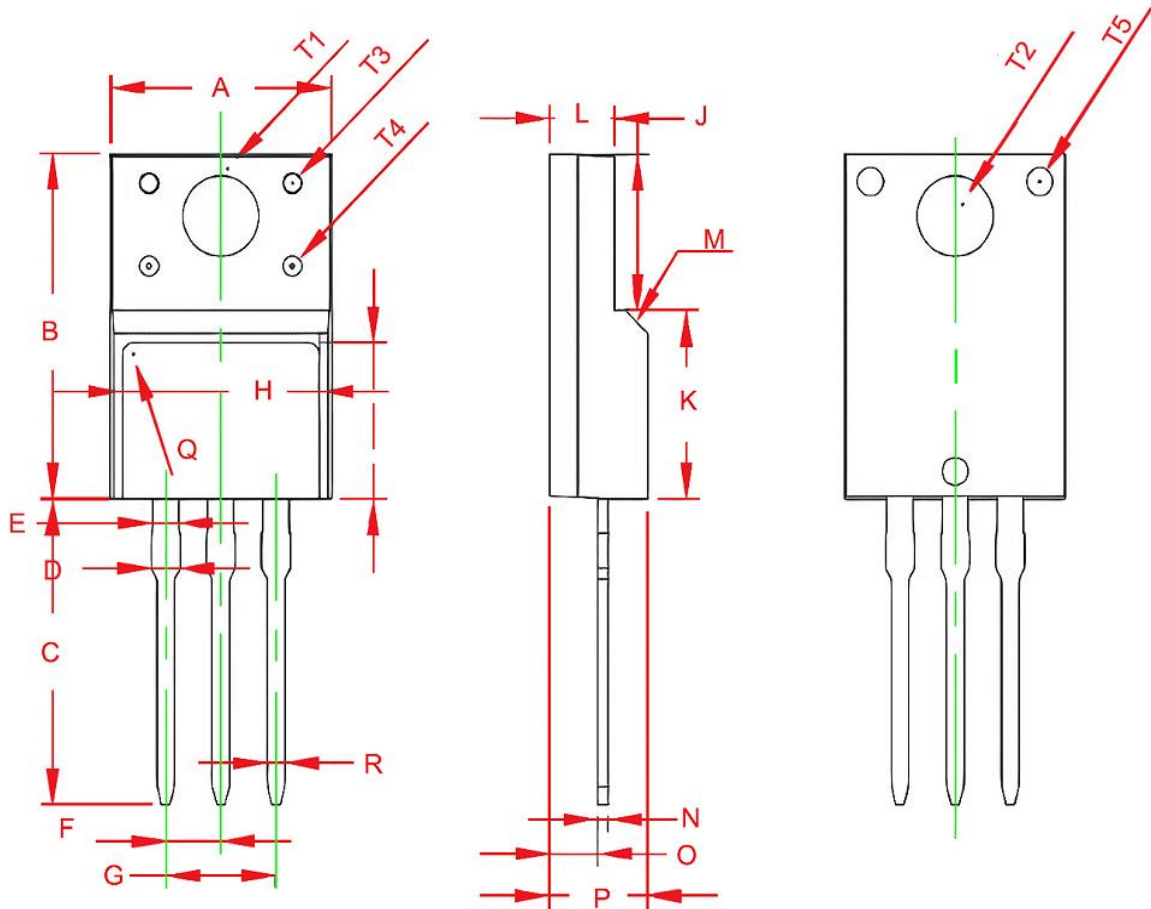

Figure 23. Safe operating area

TO-263 Package information

Symbol	Dimensions in Millimeters(mm)		Dimensions In Inches	
	Min	Max	Min	Max
A	4.300	4.800	0.169	0.189
A1	0.000	0.250	0.000	0.010
A2	2.350	2.700	0.093	0.106
b	0.700	0.940	0.028	0.037
b2	1.150	1.350	0.045	0.053
C	0.350	0.650	0.014	0.026
C1	1.200	1.400	0.047	0.055
D	8.400	9.400	0.331	0.370
D1	7.800	8.100	0.307	0.319
e	2.540 Typ.		0.100 Typ.	
E	9.850	10.300	0.388	0.406
E1	7.000	8.500	0.276	0.335
H	15.000	15.700	0.591	0.618
L	2.300	2.800	0.091	0.110
L1	0.900	1.300	0.035	0.051
L2	1.000	1.500	0.039	0.059
V	6.700 REF.		0.264 REF.	

TO-220F Package information

Symbol	Dimensions in Millimeters(mm)		Dimensions In Inches	
	Min	Max	Min	Max
A	9.960	10.360	0.392	0.407
B	15.670	16.070	0.616	0.632
C	13.140	13.540	0.517	0.533
D	1.200	1.400	0.047	0.055
E	1.200TYP		0.047TYP	
F	2.540TYP		0.100TYP	
G	5.080TYP		0.200TYP	
H	7.600	8.000	0.299	0.314
I	7.100	7.500	0.279	0.295
J	6.480	6.880	0.255	0.270
K	8.990	9.390	0.353	0.369
L	2.340	2.740	0.092	0.107
M	45°TYP		45°TYP	
N	0.490	0.520	0.019	0.020
O	2.150	2.550	0.084	0.100
P	4.500	4.900	0.177	0.192
Q	0.500TYP		0.019TYP	
S	4.5°TYP		4.5°TYP	
T1	3.450TYP		0.135TYP	
T2	3.180TYP		0.125TYP	
T3	1.500TYP		0.059TYP	
T4	1.200TYP		0.047TYP	
T5	1.500TYP		0.059TYP	
R	0.770	0.830	0.030	0.032