

**Features**

- Low  $R_{DS(on)}$  & FOM
- Extremely low switching loss
- Excellent stability and uniformity
- Fast switching and soft recovery

**Application**

- Consumer electronic power supply
- Motor control
- Synchronous-rectification
- Isolated DC/DC convertor

**Product Summary**

$V_{DS}$	$R_{DS(ON)}$ MAX	$I_D$ MAX
100V	149mΩ@10V	3A
	180mΩ@4.5V	

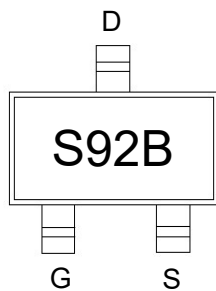

S92B: Device code

Marking and pin assignment

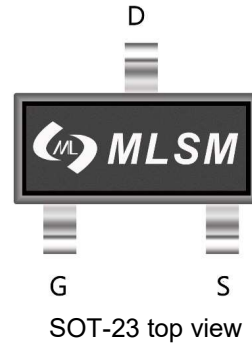

SOT-23 top view

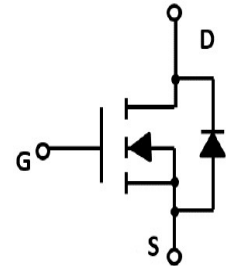

Schematic diagram



Pb-Free



RoHS



Halogen-Free

**Absolute Maximum Ratings (TA=25°C unless otherwise noted)**

Symbol	Parameter	Rating	Unit
--------	-----------	--------	------

**Common Ratings (TC=25°C Unless Otherwise Noted)**

$V_{DS}$	Drain-Source Breakdown Voltage	100	V
$V_{GS}$	Gate-Source Voltage	±20	V
$T_J$	Maximum Junction Temperature	150	°C
$T_{STG}$	Storage Temperature Range	-50 to 155	°C
$I_S$	Diode Continuous Forward Current	$T_c=25^\circ\text{C}$ 3	A

**Mounted on Large Heat Sink**

$I_{DM}$	Pulse Drain Current Tested	$T_c=25^\circ\text{C}$ 7.3	A
$I_D$	Continuous Drain Current	$T_c=25^\circ\text{C}$ 3	A
$P_D$	Maximum Power Dissipation	$T_c=25^\circ\text{C}$ 2	W
$R_{\theta JA}$	Thermal Resistance Junction-Ambient	83	°C/W

**Ordering Information (Example)**

Type	Package	Marking	Minimum Package(pcs)	Inner Box Quantity(pcs)	Outer Carton Quantity(pcs)	Delivery Mode
MLS2392B	SOT-23	S92B	3,000	45,000	180,000	7"reel

Electrical Characteristics (T <sub>J</sub> =25°C unless otherwise noted)						
Symbol	Parameter	Condition	Min	Typ	Max	Unit
<b>Static Electrical Characteristics @ T<sub>J</sub> = 25°C (unless otherwise stated)</b>						
BV <sub>(BR)DSS</sub>	Drain-Source Breakdown Voltage	V <sub>GS</sub> =0V, I <sub>D</sub> =250μA	100	--	--	V
I <sub>DSS</sub>	Zero Gate Voltage Drain Current	V <sub>DS</sub> =100V, V <sub>GS</sub> =0V	--	--	1	μA
I <sub>GSS</sub>	Gate-Body Leakage Current	V <sub>GS</sub> =±20V, V <sub>DS</sub> =0V	--	--	±100	nA
V <sub>GS(th)</sub>	Gate Threshold Voltage	V <sub>DS</sub> =V <sub>GS</sub> , I <sub>D</sub> =250μA	1.2	2.0	3.0	V
R <sub>DS(on)</sub>	Drain-Source On-State Resistance	V <sub>GS</sub> =10V, I <sub>D</sub> =2A	--	124	149	mΩ
		V <sub>GS</sub> =4.5V, I <sub>D</sub> =1A	--	138	180	mΩ
<b>Dynamic Electrical Characteristics @ T<sub>J</sub> = 25°C (unless otherwise stated)</b>						
C <sub>ISS</sub>	Input Capacitance	V <sub>DS</sub> =25V, V <sub>GS</sub> =0V, f=1MHz	--	480	--	pF
C <sub>OSS</sub>	Output Capacitance		--	30	--	pF
C <sub>RSS</sub>	Reverse Transfer Capacitance		--	22	--	pF
<b>Switching Characteristics</b>						
Q <sub>g</sub>	Total Gate Charge	V <sub>DS</sub> =30V, I <sub>D</sub> =3A, V <sub>GS</sub> =10V	--	15	--	nC
Q <sub>gs</sub>	Gate Source Charge		--	3	--	nC
Q <sub>gd</sub>	Gate Drain Charge		--	4.4	--	nC
t <sub>d(on)</sub>	Turn-on Delay Time	V <sub>DD</sub> =30V, I <sub>D</sub> =3A, V <sub>GS</sub> =10V, R <sub>G</sub> =3Ω	--	12	--	nS
t <sub>r</sub>	Turn-on Rise Time		--	7.5	--	nS
t <sub>d(off)</sub>	Turn-Off Delay Time		--	36	--	nS
t <sub>f</sub>	Turn-Off Fall Time		--	9.2	--	nS
<b>Source- Drain Diode Characteristics</b>						
V <sub>SD</sub>	Forward on voltage	T <sub>J</sub> =25°C, I <sub>S</sub> =1.8A,	--	--	1.2	V

**Typical Operating Characteristics**

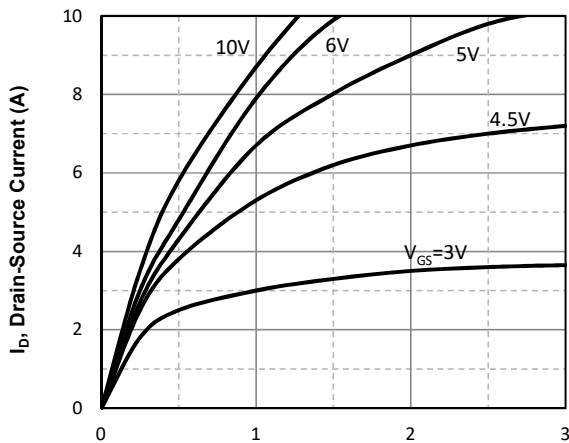

$V_{DS}$ , Drain -Source Voltage (V)  
Fig1. Typical Output Characteristics

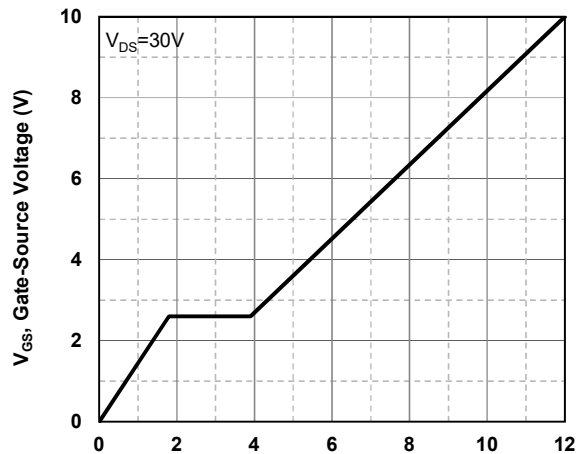

$Q_g$  -Total Gate Charge (nC)  
Fig2. Typical Gate Charge Vs. Gate-Source Voltage

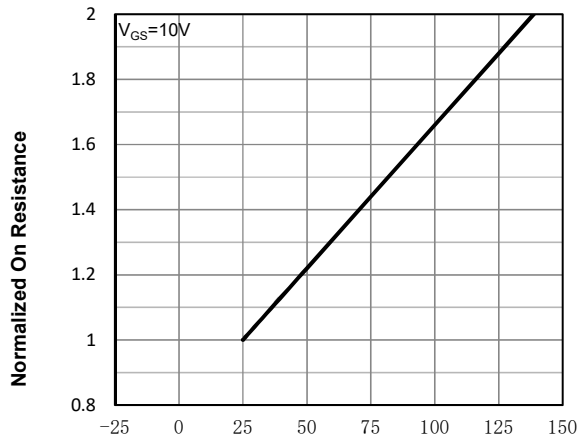

$T_j$  - Junction Temperature (°C)  
Fig3. Normalized On-Resistance Vs. Temperature

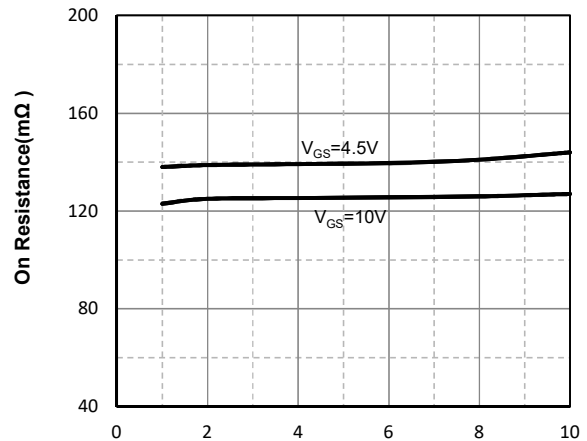

$I_D$ , Drain-Source Current (A)  
Fig4. On-Resistance Vs. Drain-Source Current

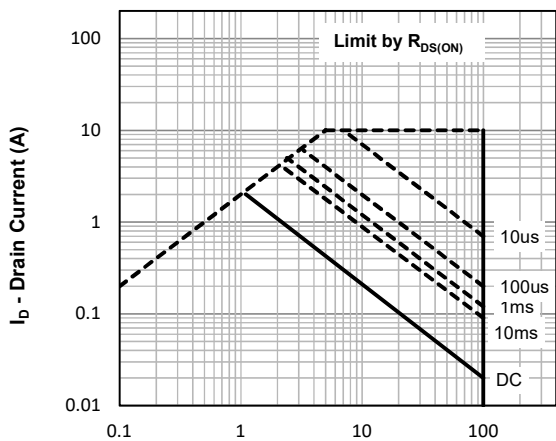

$V_{DS}$ , Drain -Source Voltage (V)  
Fig5. Maximum Safe Operating Area

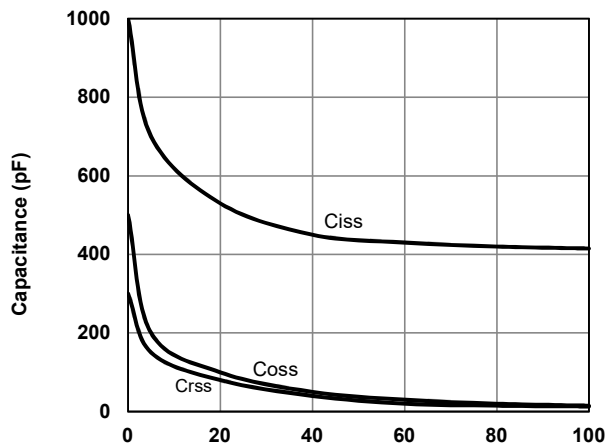

$V_{DS}$ , Drain-Source Voltage (V)  
Fig6. Typical Capacitance Vs. Drain-Source Voltage

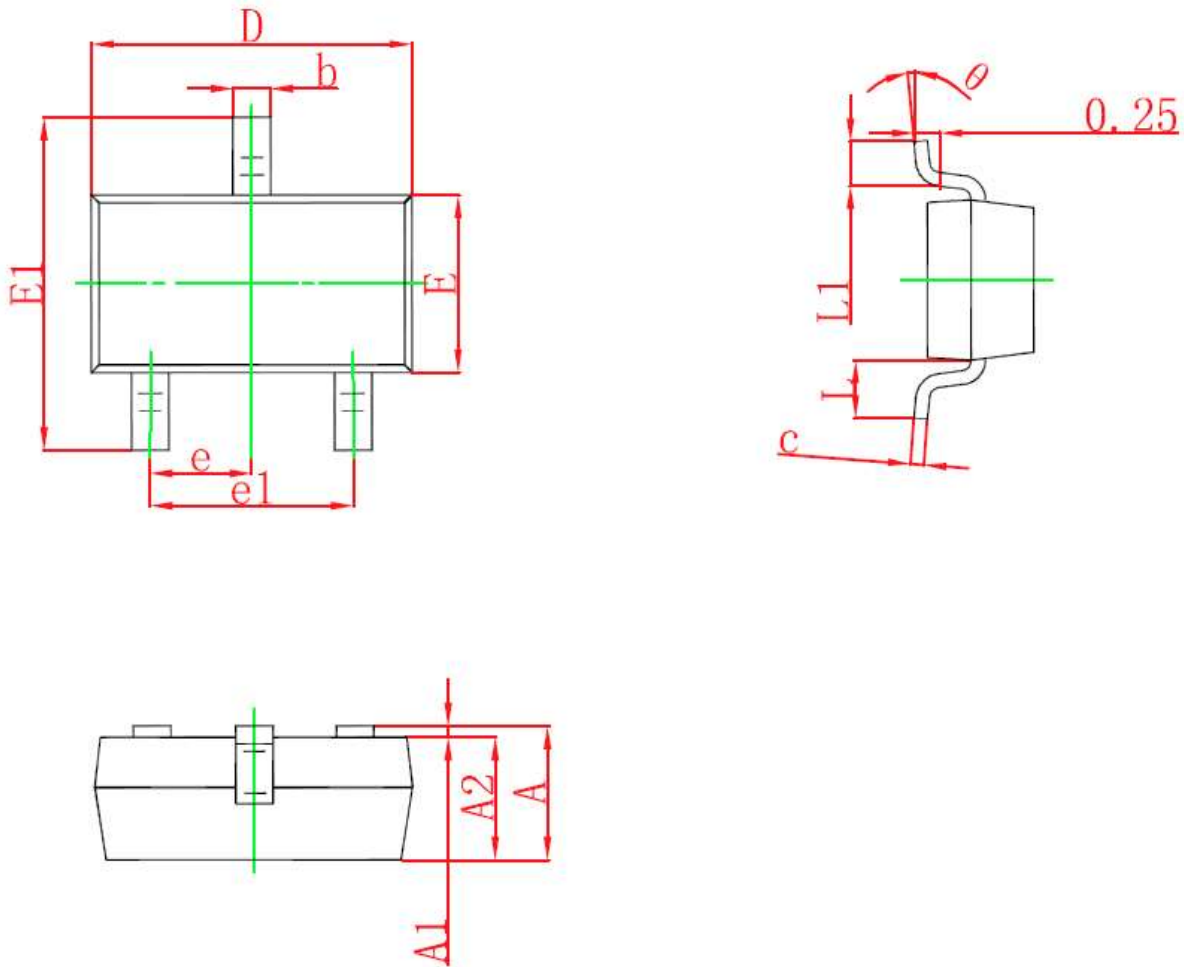
**SOT-23 Package information**

Symbol	Dimensions in Millimeters(mm)		Dimensions In Inches	
	Min	Max	Min	Max
A	0.900	1.150	0.035	0.045
A1	0.000	0.100	0.000	0.004
A2	0.900	1.050	0.035	0.041
b	0.300	0.500	0.012	0.020
c	0.080	0.150	0.003	0.006
D	2.800	3.000	0.110	0.118
E	1.200	1.400	0.047	0.055
E1	2.250	2.550	0.089	0.100
e	0.950TYP		0.037TYP	
e1	1.800	2.000	0.071	0.079
L	0.550REF		0.022REF	
L1	0.300	0.500	0.012	0.020
θ	0°	8°	0°	8°