

Features

- Leading trench technology for low $R_{DS(on)}$
- Low Gate Charge

Product Summary

V_{DS}	$R_{DS(on)}$ MAX	I_D MAX
-20V	65mΩ@-4.5V	-3.7A
	90mΩ@-2.5V	

Application

- Video monitor
- Power management

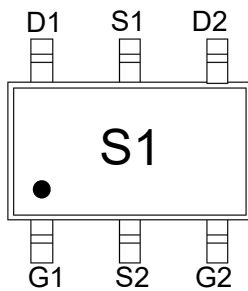

S1: Device code

Marking and pin assignment

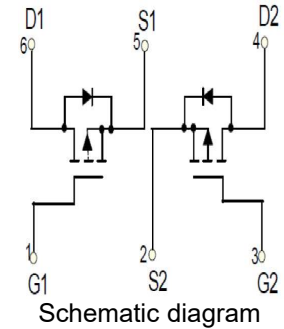
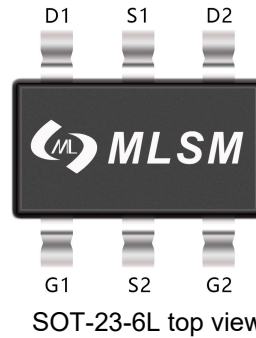

Halogen-Free

Absolute Maximum Ratings (TA=25°C unless otherwise noted)

Symbol	Parameter	Rating	Unit
--------	-----------	--------	------

Common Ratings (TC=25°C Unless Otherwise Noted)

V_{DS}	Drain-Source Breakdown Voltage	-20	V
V_{GS}	Gate-Source Voltage	±10	V
T_J	Maximum Junction Temperature	150	°C
T_{STG}	Storage Temperature Range	-55 to 150	°C
I_S	Diode Continuous Forward Current	$T_c=25^\circ\text{C}$ -3.7	A

Mounted on Large Heat Sink

I_{DM}	Pulse Drain Current Tested	$T_c=25^\circ\text{C}$ -16	A
I_D	Continuous Drain Current	$T_c=25^\circ\text{C}$ -3.7	A
P_D	Maximum Power Dissipation	$T_c=25^\circ\text{C}$ 1.3	W
$R_{\theta JA}$	Thermal Resistance Junction-to-Ambient	96	°C/W

Ordering Information (Example)

Type	Package	Marking	Minimum Package(pcs)	Inner Box Quantity(pcs)	Outer Carton Quantity(pcs)	Delivery Mode
MLSL2301A	SOT-23-6L	S1	3,000	45,000	180,000	7"reel

Electrical Characteristics (T _J =25°C unless otherwise noted)						
Symbol	Parameter	Condition	Min	Typ	Max	Unit
Static Electrical Characteristics @ T_J = 25°C (unless otherwise stated)						
B _{V(BR)DSS}	Drain-Source Breakdown Voltage	V _{GS} =0V, I _D =-250μA	-20	-	-	V
I _{DSS}	Zero Gate Voltage Drain Current	V _{DS} =-20V, V _{GS} =0V	--	-	-1	μA
I _{GSS}	Gate-Body Leakage Current	V _{GS} =±10V, V _{DS} =0V	--	-	±100	nA
V _{GS(th)}	Gate Threshold Voltage	V _{DS} =V _{GS} , I _D =-250μA	-0.4	-0.62	-1.0	V
R _{DS(on)}	Drain-Source On-State Resistance	V _{GS} =-4.5V, I _D =-3.7A	--	55	65	mΩ
		V _{GS} =-2.5V, I _D =-3.0A	--	73	90	mΩ
		V _{GS} =-1.8V, I _D =-2.5A	--	100	180	mΩ
Dynamic Electrical Characteristics @ T_J = 25°C (unless otherwise stated)						
C _{ISS}	Input Capacitance	V _{DS} =-10V, V _{GS} =0V, f=1MHz	-	438	-	pF
C _{OSS}	Output Capacitance		-	76	-	pF
C _{RSS}	Reverse Transfer Capacitance		-	62	-	pF
Switching Characteristics						
Q _g	Total Gate Charge	V _{DS} =-10V, I _D =-3.7A, V _{GS} =-4.5V	-	5.41	-	nC
Q _{gs}	Gate Source Charge		-	1.17	-	nC
Q _{gd}	Gate Drain Charge		-	1.24	-	nC
t _{d(on)}	Turn-on Delay Time	V _{DD} =-10V, I _D =-1A, V _{GS} =-4.5V, R _G =3Ω	-	6.4	-	nS
t _r	Turn-on Rise Time		-	21.8	-	nS
t _{d(off)}	Turn-Off Delay Time		-	37.4	-	nS
t _f	Turn-Off Fall Time		-	34	-	nS
Source- Drain Diode Characteristics						
V _{SD}	Forward on voltage	T _J =25°C, I _S =-3.7A	-	-	-1.2	V

Typical Operating Characteristics

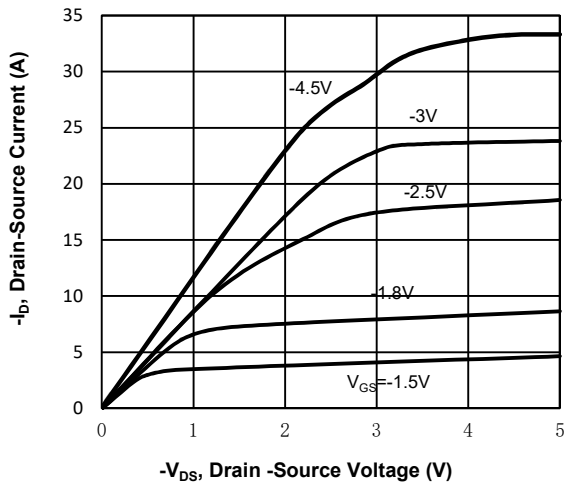

Fig1. Typical Output Characteristics

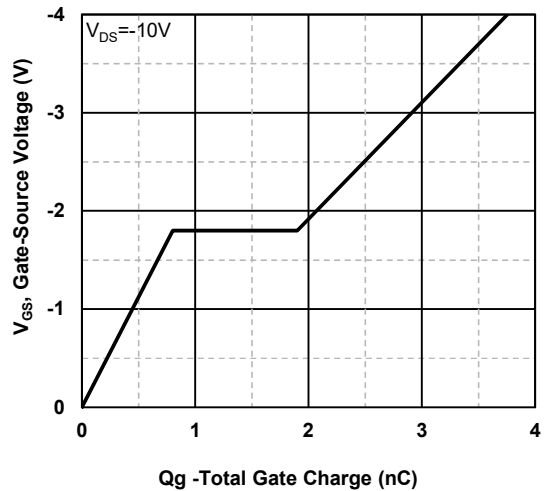

Fig2. Typical Gate Charge Vs. Gate-Source Voltage

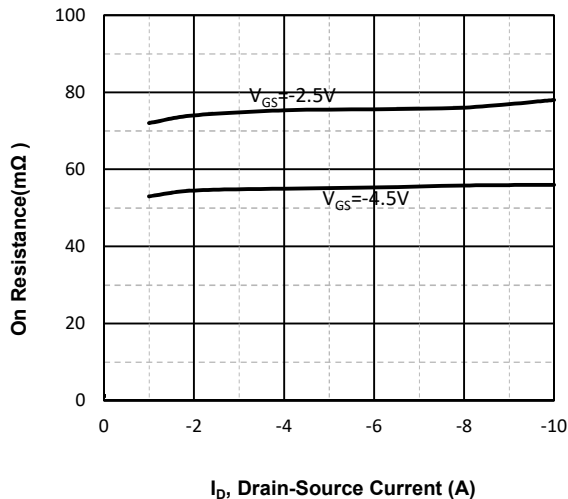

Fig3. Drain-Source on Resistance

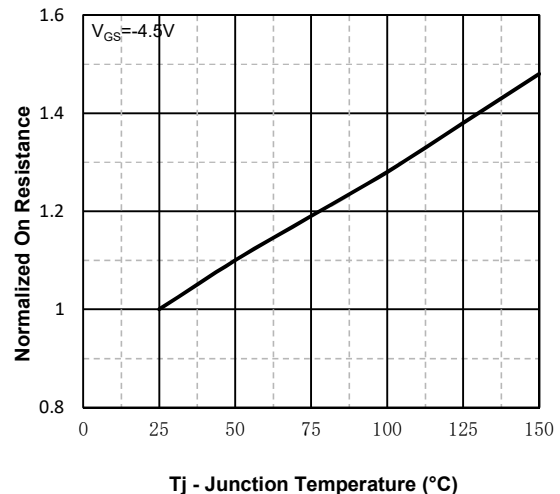

Fig4. Normalized On-Resistance Vs. Temperature

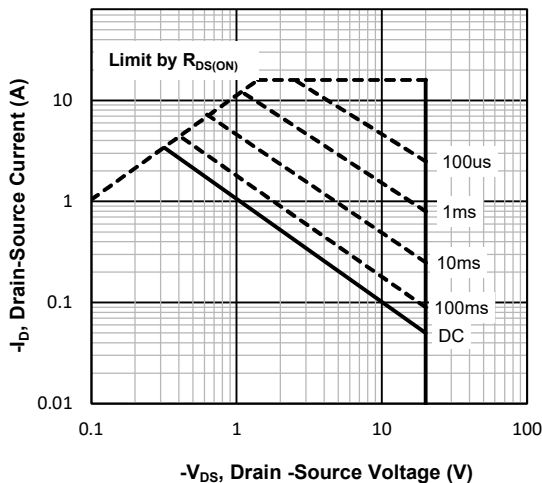

Fig5. Maximum Safe Operating Area

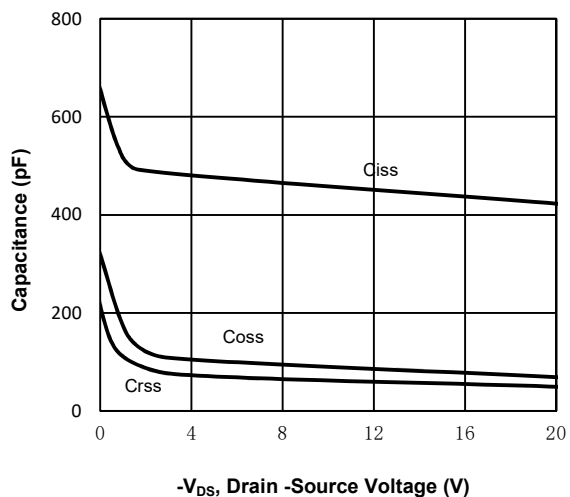
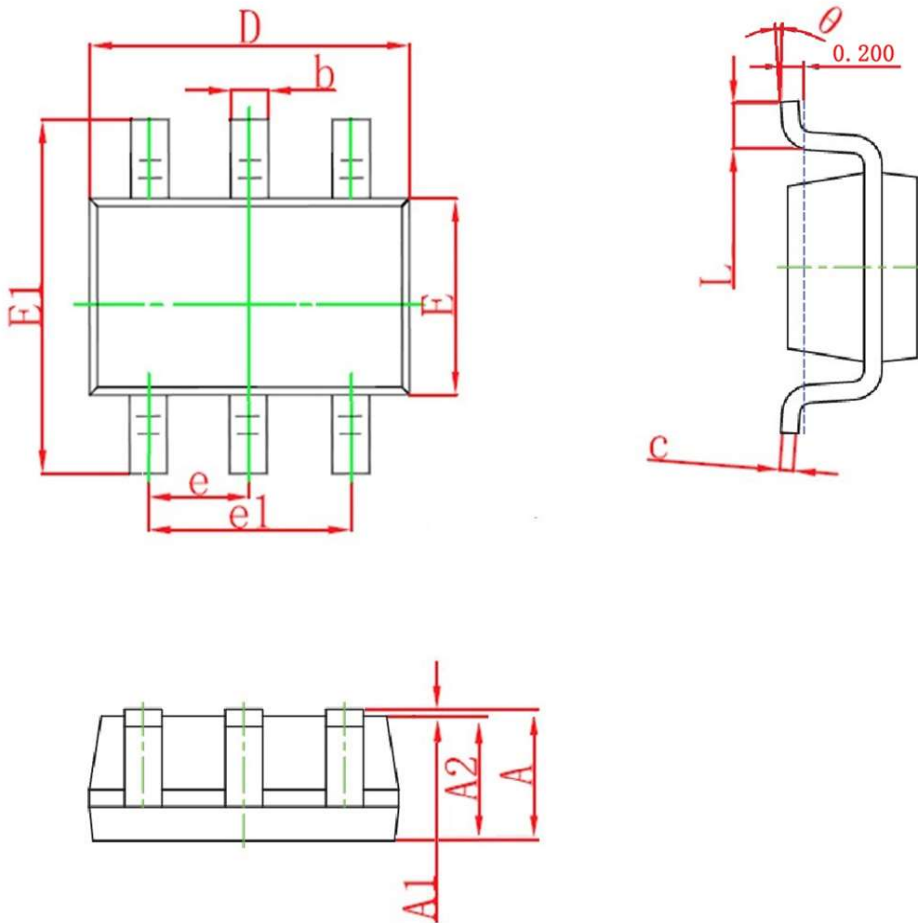

Fig6 Typical Capacitance Vs. Drain-Source Voltage

SOT-23-6L Package information

Symbol	Dimensions in Millimeters(mm)		Dimensions In Inches	
	Min	Max	Min	Max
A	1.050	1.250	0.041	0.049
A1	0.000	0.100	0.000	0.004
A2	1.000	1.200	0.039	0.047
b	0.300	0.500	0.012	0.020
c	0.100	0.200	0.004	0.008
D	2.820	3.020	0.111	0.119
E	1.500	1.700	0.059	0.067
E1	2.600	3.000	0.102	0.118
e	0.950TYP		0.037TYP	
e1	1.800	2.000	0.071	0.079
L	0.300	0.600	0.012	0.024
K	0°	8°	0°	8°