

**Features**

- High density cell design for ultra low  $R_{DS(ON)}$
- Fully characterized avalanche voltage and current
- Excellent package for good heat dissipation

**Product Summary**

$V_{DS}$	$R_{DS(ON)}$ TYP	$I_D$
30V	9m $\Omega$ @10V	10A
	11m $\Omega$ @4.5V	

**Application**

- Power switching application

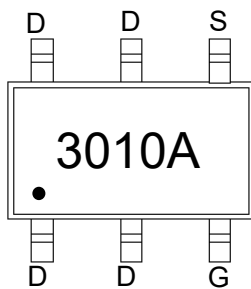

3010A: Device code

Marking and pin assignment

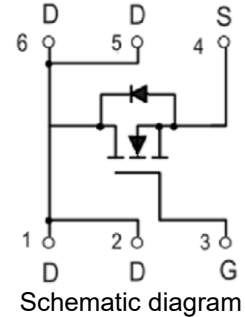
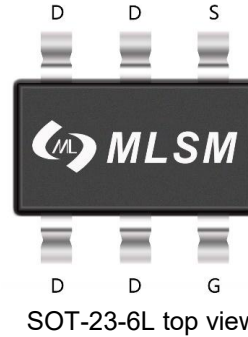

Halogen-Free

**Absolute Maximum Ratings (TA=25°C unless otherwise noted)**

Symbol	Parameter	Rating	Unit
<b>Common Ratings (TC=25°C Unless Otherwise Noted)</b>			
$V_{DS}$	Drain-Source Breakdown Voltage	30	V
$V_{GS}$	Gate-Source Voltage	$\pm 20$	V
$T_J$	Maximum Junction Temperature	150	$^{\circ}C$
$T_{STG}$	Storage Temperature Range	-50 to 155	$^{\circ}C$
$I_S$	Diode Continuous Forward Current	$T_c=25^{\circ}C$ 10	A
<b>Mounted on Large Heat Sink</b>			
$I_{DM}$	Pulse Drain Current Tested	$T_c=25^{\circ}C$ 40	A
$I_D$	Continuous Drain Current	$T_c=25^{\circ}C$ 10	A
$P_D$	Maximum Power Dissipation	$T_c=25^{\circ}C$ 1.25	W
$R_{\theta JA}$	Thermal Resistance Junction-Ambient	325	$^{\circ}C/W$

**Ordering Information (Example)**

Type	Package	Marking	Minimum Package(pcs)	Inner Box Quantity(pcs)	Outer Carton Quantity(pcs)	Delivery Mode
MLSL3010A	SOT-23-6L	3010A	3,000	45,000	180,000	7"reel

Electrical Characteristics (T <sub>J</sub> =25°C unless otherwise noted)						
Symbol	Parameter	Condition	Min	Typ	Max	Unit
<b>Static Electrical Characteristics @ T<sub>J</sub> = 25°C (unless otherwise stated)</b>						
BV <sub>(BR)DSS</sub>	Drain-Source Breakdown Voltage	V <sub>GS</sub> =0V, I <sub>D</sub> =250μA	30	--	--	V
I <sub>DSS</sub>	Zero Gate Voltage Drain Current	V <sub>DS</sub> =30V, V <sub>GS</sub> =0V	--	--	1.0	μA
I <sub>GSS</sub>	Gate-Body Leakage Current	V <sub>GS</sub> =±20V, V <sub>DS</sub> =0V	--	--	±100	nA
V <sub>GS(th)</sub>	Gate Threshold Voltage	V <sub>DS</sub> =V <sub>GS</sub> , I <sub>D</sub> =250μA	1.0	1.5	2.5	V
R <sub>DS(on)</sub>	Drain-Source On-State Resistance	V <sub>GS</sub> =10V, I <sub>D</sub> =8A	--	9	13	mΩ
		V <sub>GS</sub> =4.5V, I <sub>D</sub> =5A	--	11	22	mΩ
<b>Dynamic Electrical Characteristics @ T<sub>J</sub> = 25°C (unless otherwise stated)</b>						
C <sub>ISS</sub>	Input Capacitance	V <sub>DS</sub> =15V, V <sub>GS</sub> =0V, f=1MHz	--	1055	--	pF
C <sub>OSS</sub>	Output Capacitance		--	180	--	pF
C <sub>RSS</sub>	Reverse Transfer Capacitance		--	130	--	pF
<b>Switching Characteristics</b>						
Q <sub>g</sub>	Total Gate Charge	V <sub>DS</sub> =15V, I <sub>D</sub> =6A, V <sub>GS</sub> =10V	--	25	--	nC
Q <sub>gs</sub>	Gate Source Charge		--	3.5	--	nC
Q <sub>gd</sub>	Gate Drain Charge		--	6	--	nC
t <sub>d(on)</sub>	Turn-on Delay Time	V <sub>DS</sub> =15V, R <sub>L</sub> =1.8Ω, V <sub>GS</sub> =10V, R <sub>G</sub> =3Ω	--	5	--	nS
t <sub>r</sub>	Turn-on Rise Time		--	12	--	nS
t <sub>d(off)</sub>	Turn-Off Delay Time		--	19	--	nS
t <sub>f</sub>	Turn-Off Fall Time		--	6	--	nS
<b>Source- Drain Diode Characteristics</b>						
V <sub>SD</sub>	Forward on voltage	T <sub>J</sub> =25°C, I <sub>S</sub> =8A	--	--	1.2	V

**Typical Operating Characteristics**

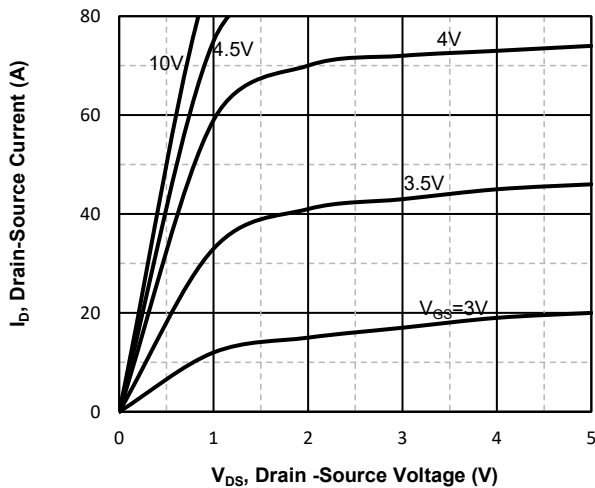

**Fig1. Typical Output Characteristics**

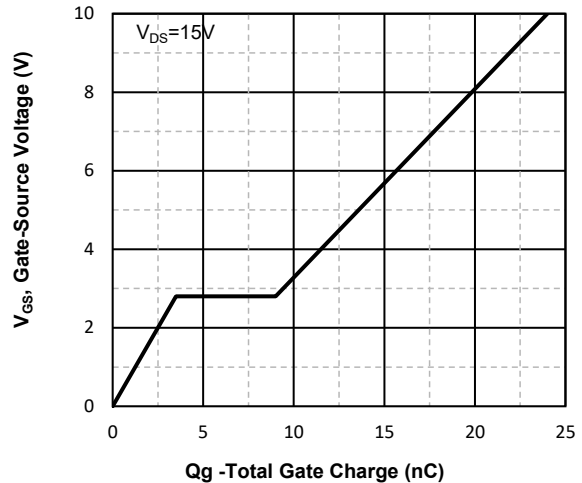

**Fig2. Typical Gate Charge Vs. Gate-Source Voltage**

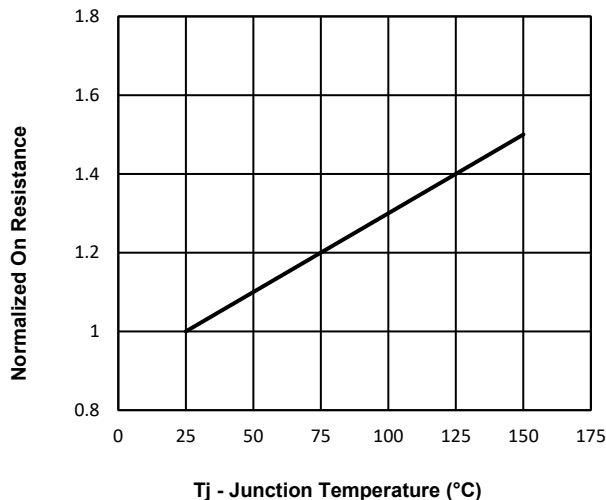

**Fig3. Normalized On-Resistance Vs. Temperature**

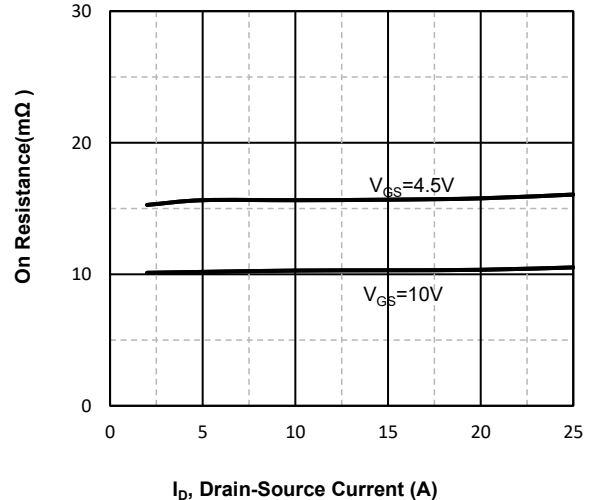

**Fig4. On-Resistance Vs. Drain-Source Current**

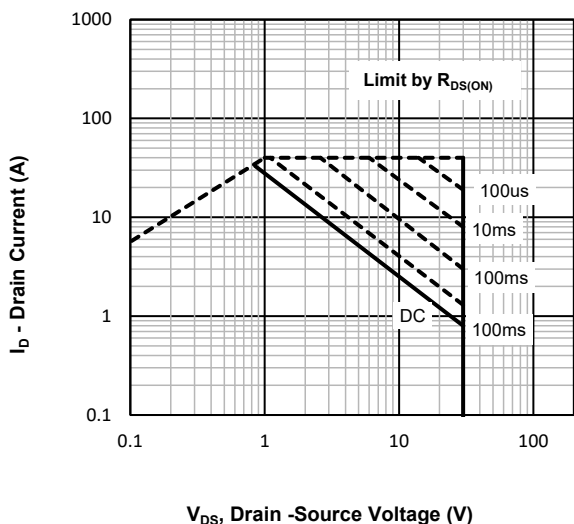

**Fig5. Maximum Safe Operating Area**

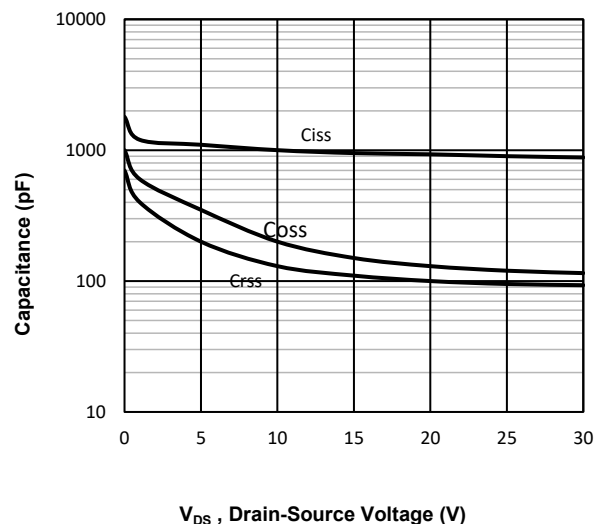

**Fig6 Typical Capacitance Vs. Drain-Source**

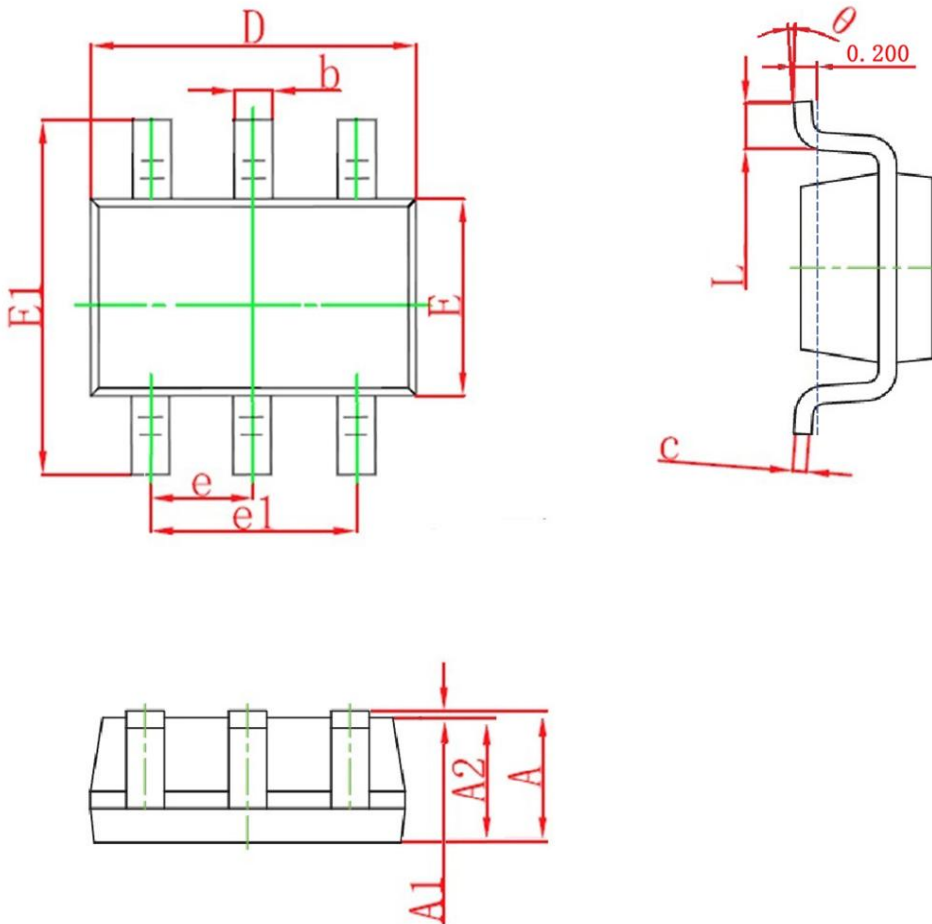
**SOT-23-6L Package information**

Symbol	Dimensions in Millimeters(mm)		Dimensions In Inches	
	Min	Max	Min	Max
A	1.050	1.250	0.041	0.049
A1	0.000	0.100	0.000	0.004
A2	1.000	1.200	0.039	0.047
b	0.300	0.500	0.012	0.020
c	0.100	0.200	0.004	0.008
D	2.820	3.020	0.111	0.119
E	1.500	1.700	0.059	0.067
E1	2.600	3.000	0.102	0.118
e	0.950TYP		0.037TYP	
e1	1.800	2.000	0.071	0.079
L	0.300	0.600	0.012	0.024
K	0°	8°	0°	8°