

### Features

- Ultra Low On-Resistance
- Ultra Low FOM ( $R_{DS(ON)} \times Qg$ )
- Good stability and uniformity with high EAS
- Excellent package for good heat dissipation

### Application

- Motor Drivers

### Product Summary

$V_{DS}$	$R_{DS(ON)}$ TYP	$I_D$
60V	6.2m $\Omega$ @10V	50A

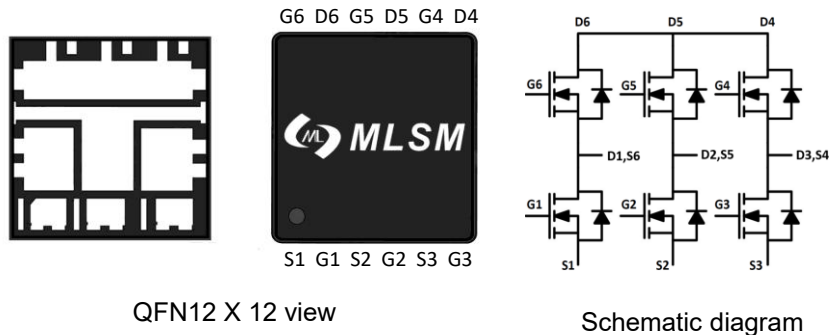

MM0G650A: Device code  
 XXXX: Code  
 Solid dot: Pin1 indicator

Pin 1

Marking and pin assignment



Absolute Maximum Ratings (TA=25°C unless otherwise noted)				
Symbol	Parameter		Rating	Unit
<b>Common Ratings (TC=25°C Unless Otherwise Noted)</b>				
$V_{DS}$	Drain-Source Breakdown Voltage		60	V
$V_{GS}$	Gate-Source Voltage		$\pm 20$	V
$T_J$	Maximum Junction Temperature		150	°C
$T_{STG}$	Storage Temperature Range		-50 to 155	°C
$I_S$	Diode Continuous Forward Current	$T_c=25^\circ\text{C}$	50	A
<b>Mounted on Large Heat Sink</b>				
$I_{DM}$	Pulse Drain Current Tested	$T_c=25^\circ\text{C}$	200	A
$I_D$	Continuous Drain Current	$T_c=25^\circ\text{C}$	50	A
$P_D$	Maximum Power Dissipation	$T_c=25^\circ\text{C}$	66	W
$E_{AS}$	Single Pulse Avalanche Energy		320	mJ
$R_{\theta JA}$	Thermal Resistance Junction-Ambient		60	°C/W

Ordering Information (Example)						
Type	Package	Marking	Minimum Package(pcs)	Inner Box Quantity(pcs)	Outer Carton Quantity(pcs)	Delivery Mode
MM0G650A	QFN12*12	MM0G650A	2,000	4,000	28,000	13"reel

**Electrical Characteristics (T<sub>J</sub>=25°C unless otherwise noted)**

Symbol	Parameter	Condition	Min	Typ	Max	Unit
<b>Static Electrical Characteristics @ T<sub>J</sub> = 25°C (unless otherwise stated)</b>						
BV <sub>(BR)DSS</sub>	Drain-Source Breakdown Voltage	V <sub>GS</sub> =0V, I <sub>D</sub> =250μA	60	--	--	V
I <sub>DSS</sub>	Zero Gate Voltage Drain Current	V <sub>DS</sub> =60V, V <sub>GS</sub> =0V	--	--	1.0	μA
I <sub>GSS</sub>	Gate-Body Leakage Current	V <sub>GS</sub> =±20V, V <sub>DS</sub> =0V	--	--	±100	nA
V <sub>GS(th)</sub>	Gate Threshold Voltage	V <sub>DS</sub> =V <sub>GS</sub> , I <sub>D</sub> =250μA	2.0	--	4.0	V
R <sub>DS(on)</sub>	Drain-Source On-State Resistance	V <sub>GS</sub> =10V, I <sub>D</sub> =15A	--	6.2	7.6	mΩ
<b>Dynamic Electrical Characteristics @ T<sub>J</sub> = 25°C (unless otherwise stated)</b>						
C <sub>ISS</sub>	Input Capacitance	V <sub>DS</sub> =30V, V <sub>GS</sub> =0V, f=1MHz	--	3100	--	pF
C <sub>OSS</sub>	Output Capacitance		--	215	--	pF
C <sub>RSS</sub>	Reverse Transfer Capacitance		--	181	--	pF
<b>Switching Characteristics</b>						
Q <sub>g</sub>	Total Gate Charge	V <sub>DS</sub> =30V, I <sub>D</sub> =25A, V <sub>GS</sub> =10V	--	63	--	nC
Q <sub>gs</sub>	Gate Source Charge		--	16	--	nC
Q <sub>gd</sub>	Gate Drain Charge		--	14	--	nC
t <sub>d(on)</sub>	Turn-on Delay Time	V <sub>DS</sub> =30V, I <sub>D</sub> =2.5Ω, V <sub>GS</sub> =10V, R <sub>G</sub> =2.5Ω	--	75	--	nS
t <sub>r</sub>	Turn-on Rise Time		--	48	--	nS
t <sub>d(off)</sub>	Turn-Off Delay Time		--	150	--	nS
t <sub>f</sub>	Turn-Off Fall Time		--	80	--	nS
<b>Source- Drain Diode Characteristics</b>						
V <sub>SD</sub>	Forward on voltage	T <sub>J</sub> =25°C, I <sub>S</sub> =15A	--	--	1.2	V

 EAS condition: T<sub>J</sub>=25°C, V<sub>DD</sub>=30V, V<sub>GS</sub>=10V, L=0.5mH

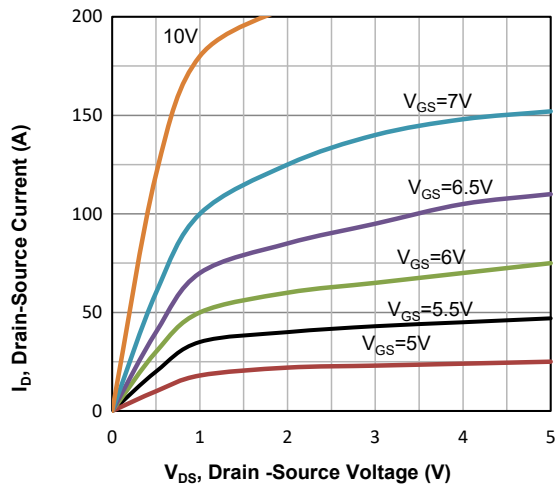
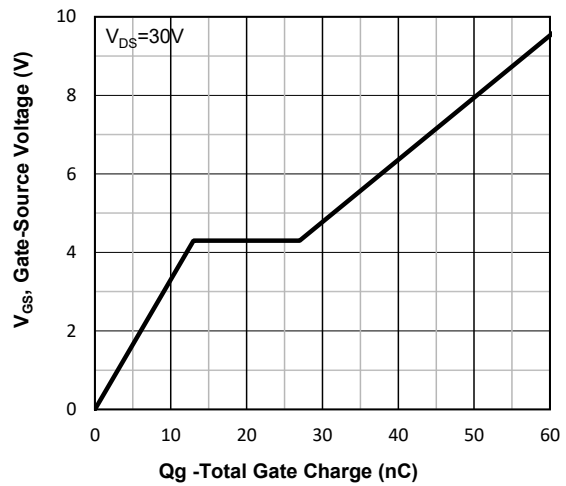
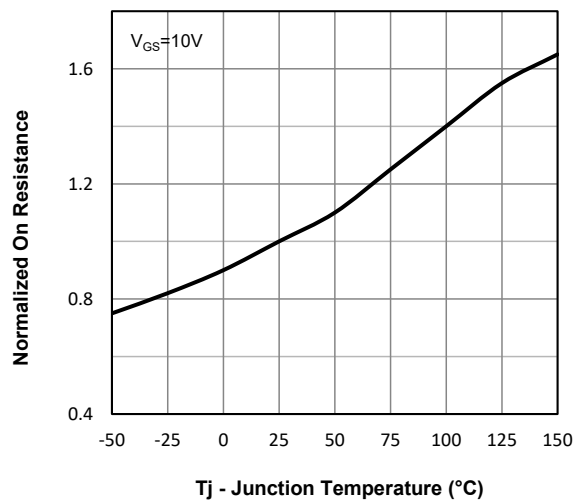
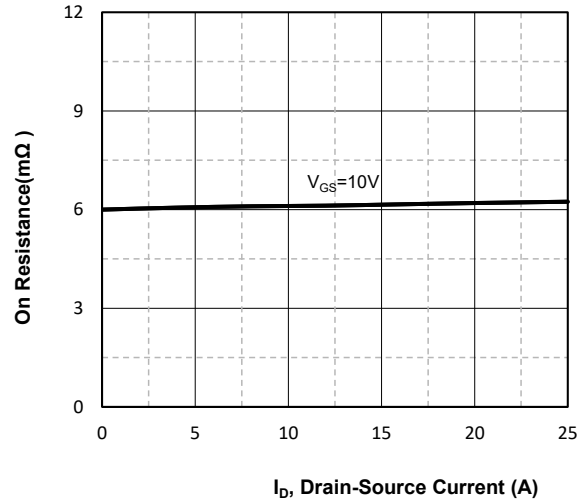
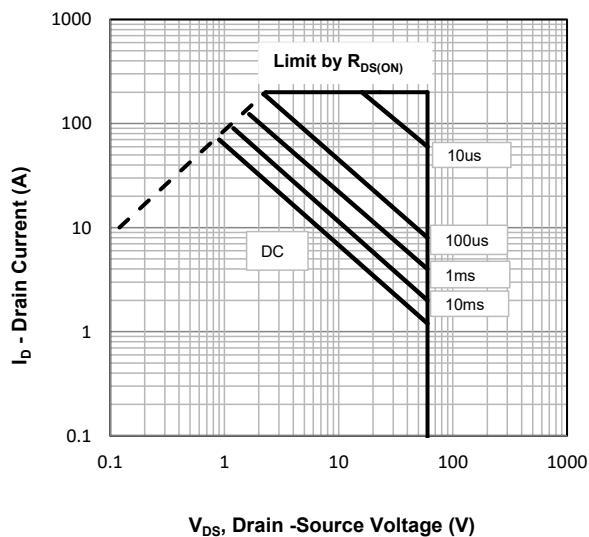
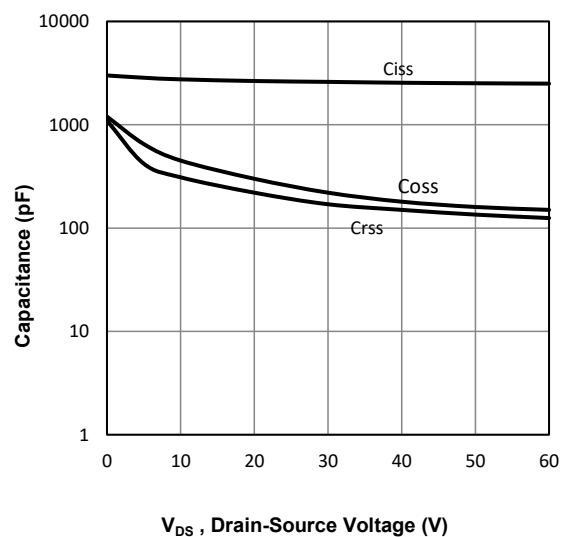
**Typical Operating Characteristics**

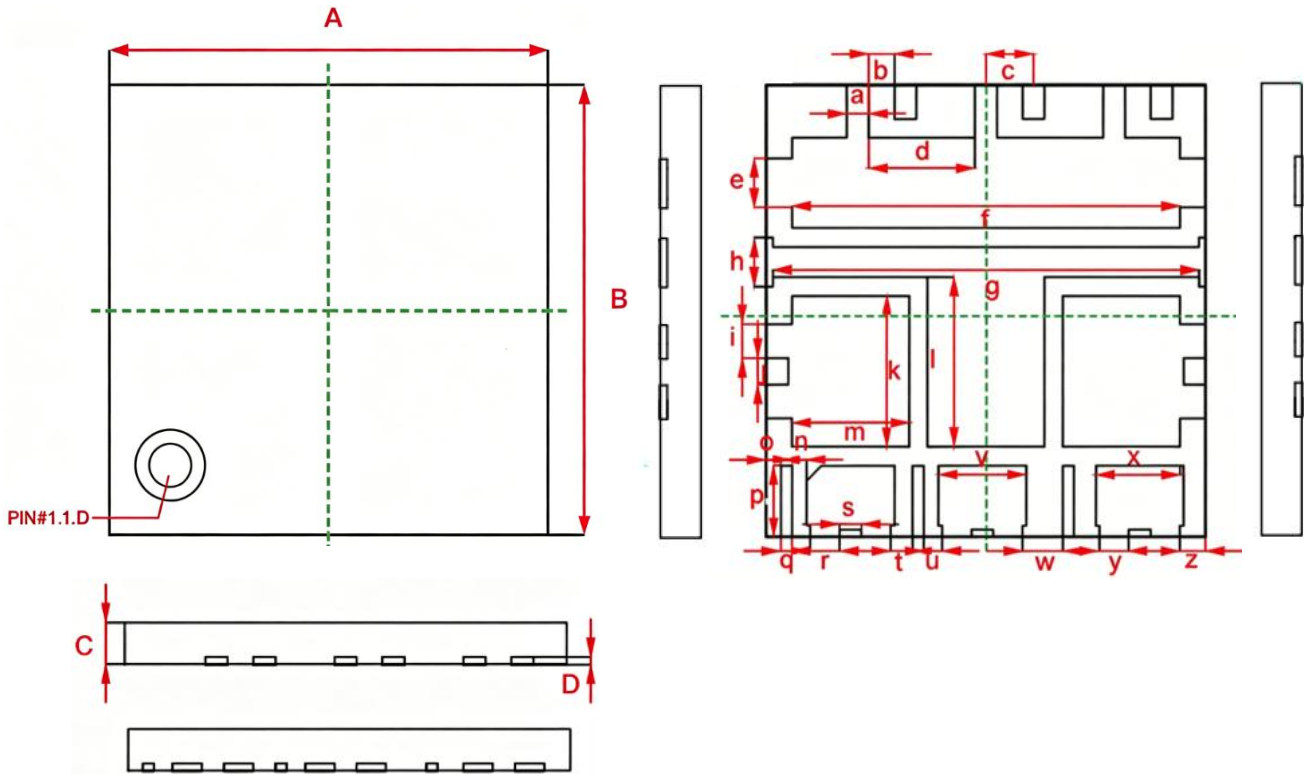
**Fig1. Typical Output Characteristics**

**Fig2. Typical Gate Charge Vs. Gate-Source Voltage**

**Fig3. Normalized On-Resistance Vs. Temperature**

**Fig4. On-Resistance Vs. Drain-Source Current**

**Fig5. Maximum Safe Operating Area**

**Fig6 Typical Capacitance Vs. Drain-Source Voltage**

**QFN12X12 Package information**

Symbol	Dimensions in Millimeters(mm)		Dimensions In Inches	
	Min	Max	Min	Max
A	11.500	12.500	0.455	0.494
B	11.500	12.500	0.455	0.494
C	1.050	1.150	0.042	0.045
D	0.200	0.205	0.008	0.008
a	0.580	0.620	0.023	0.025
b	0.680	0.720	0.027	0.028
c	1.250	1.350	0.049	0.053
d	2.800	3.000	0.111	0.119
e	1.250	1.350	0.049	0.053
f	10.500	10.700	0.415	0.423
g	11.500	11.700	0.455	0.463
h	1.250	1.350	0.049	0.053
i	0.850	0.950	0.034	0.038
j	0.680	0.720	0.027	0.028
k	3.800	4.200	0.150	0.166
l	4.400	4.600	0.174	0.182
m	3.150	3.250	0.125	0.129
n	0.380	0.420	0.015	0.017
o	0.380	0.420	0.015	0.017
p	1.880	1.920	0.074	0.076
q	0.280	0.320	0.011	0.013
r	0.850	0.950	0.034	0.038
s	0.580	0.620	0.023	0.025
t	0.580	0.620	0.023	0.025
u	0.480	0.520	0.019	0.021
v	2.200	2.600	0.087	0.103
w	1.000	1.200	0.040	0.047
x	2.250	2.350	0.089	0.093
y	0.750	0.850	0.030	0.034
z	0.680	0.720	0.027	0.028