

Features

- Wide Bandgap SiC MOSFET Technology
- Low On-Resistance with High Blocking Voltage
- Low Capacitances with High-Speed Switching
- Low Reverse Recovery(Qrr)
- Easy to Parallel and Simple to Drive
- Robust against Parasitic Turn on Even 0V Turn off Gate Voltage

Application

- Switch Mode Power Supplies
- High Voltage DC/DC Converters
- Battery Chargers
- Motor Drives
- Pulsed Power Applications

Product Summary

V_{DS}	$R_{DS(ON)}$ TYP	I_D
750V	340mΩ@15V	12A

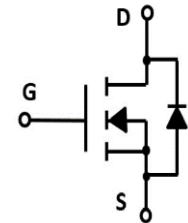

TO-252

TO-220F

Halogen-Free

Absolute Maximum Ratings (TA=25°C unless otherwise noted)

Symbol	Parameter	Rating	Unit
Common Ratings (TC=25°C Unless Otherwise Noted)			
V_{DS}	Drain-Source Breakdown Voltage	750	V
V_{GS}	Gate-Source Voltage	-10/+22	V
V_{GSop}	Recommended Operation Voltage of Gate to Source	0/+15	V
T_J, T_{STG}	Operating and Storage Temperature Range	-55 to 175	°C
I_S	Diode Continuous Forward Current	Tc=25°C 12	A
I_{DM}	Pulse Drain Current Tested	Tc=25°C 24	A
		Tc=175°C 20	A
I_D	Continuous Drain Current	Tc=25°C 12	A
		Tc=175°C 10	A
P_D	Maximum Power Dissipation	Tc=25°C 24	W
E_{AS}	Single Pulsed Avalanche Energy	50	mJ
$R_{th(j-c)}$	Thermal Resistance from Junction-Case	6.25	°C/W

Ordering Information (Example)

Type	Package	Marking	Minimum Package(pcs)	Inner Box Quantity(pcs)	Outer Carton Quantity(pcs)	Delivery Mode
MU340C7F	TO-252	MU340C7F	2,500	5,000	35,000	13"reel
MYF340C7F	TO-220F	MYF340C7F	50	1,000	5,000	/

Electrical Characteristics (T _J =25°C unless otherwise noted)						
Symbol	Parameter	Condition	Min	Typ	Max	Unit
Static Electrical Characteristics @ T_J = 25°C (unless otherwise stated)						
BV _{(BR)DSS}	Drain-Source Breakdown Voltage	V _{GS} =0V, I _D =500μA	750	830	--	V
I _{DSS}	Zero Gate Voltage Drain Current	V _{DS} =750V, V _{GS} =0V	--	--	10	μA
I _{GSS}	Gate-Body Leakage Current	V _{GS} =18V, V _{DS} =0V	--	--	250	nA
V _{GS(th)}	Gate Threshold Voltage	V _{DS} =V _{GS} , I _D =1.8mA	3.0	--	5.0	V
R _{DS(on)}	Drain-Source On-State Resistance	V _{GS} =18V, I _D =5A	--	260	--	mΩ
		V _{GS} =18V, I _D =5A, T _J =175°C	--	270	--	mΩ
		V _{GS} =15V, I _D =5A	--	330	390	mΩ
		V _{GS} =15V, I _D =5A, T _J =175°C	--	355	--	mΩ
Dynamic Electrical Characteristics @ T_J = 25°C (unless otherwise stated)						
C _{ISS}	Input Capacitance	V _{DS} =500V, V _{GS} =0V, f=1MHz	--	254	--	pF
C _{OSS}	Output Capacitance		--	20.2	--	pF
C _{RSS}	Reverse Transfer Capacitance		--	2.4	--	pF
Switching Characteristics						
Q _g	Total Gate Charge	V _{DS} =500V, I _D =5A, V _{GS} =0/15V	--	8.8	--	nC
Q _{gs}	Gate Source Charge		--	3.3	--	nC
Q _{gd}	Gate Drain Charge		--	1.2	--	nC
t _{d(on)}	Turn-on Delay Time	V _{DD} =500V, I _D =5A, V _{GS} =0/15V, R _G =10Ω	--	24	--	nS
t _r	Turn-on Rise Time		--	42	--	nS
t _{d(off)}	Turn-Off Delay Time		--	26.8	--	nS
t _f	Turn-Off Fall Time		--	76	--	nS
R _g	Gate Resistance	V _{AC} =25mV, f=1MHz	--	25	--	Ω
Source- Drain Diode Characteristics						
V _{SD}	Forward on voltage	T _J =25°C, I _S =3A	--	3.5	--	V
I _S	Continuous Diode Forward Current	V _{GS} =0V, T _J =25°C	--	12	--	A
t _{rr}	Reverse Recovery Time	V _{GS} = 0V, I _{SD} =5A, V _R =500V, di/dt=530A/us, T _J =25°C	--	10.9	--	ns
Q _{rr}	Reverse Recovery Charge		--	28	--	nC
I _{rrm}	Peak Reverse Recovery Current		--	3.9	--	A

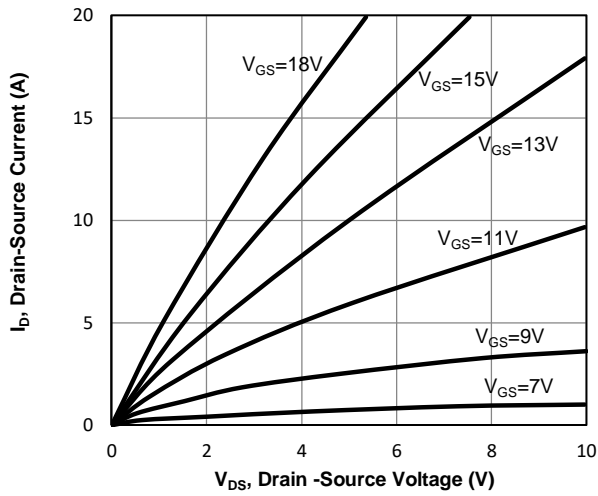
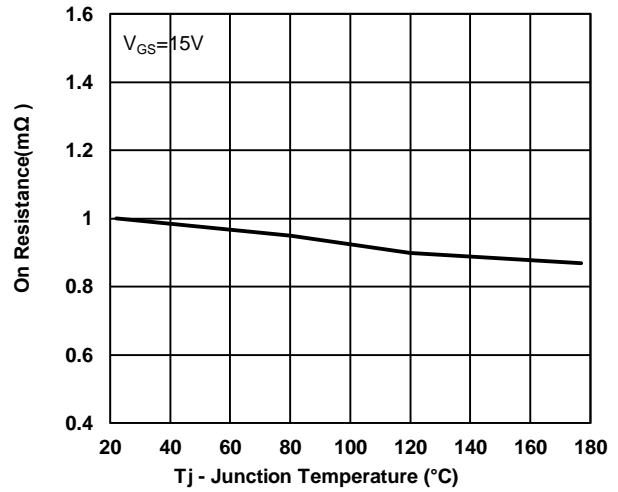
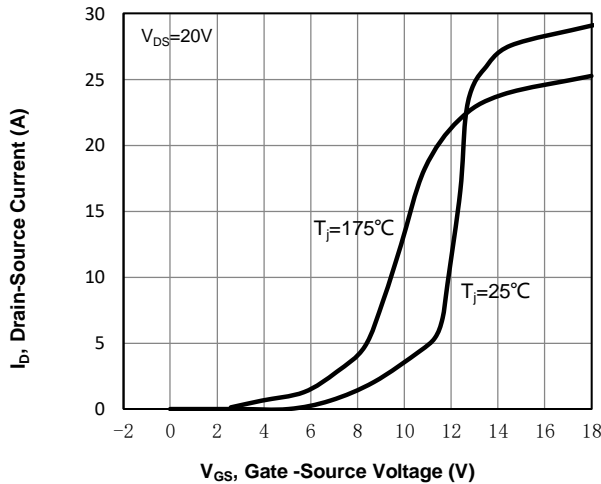
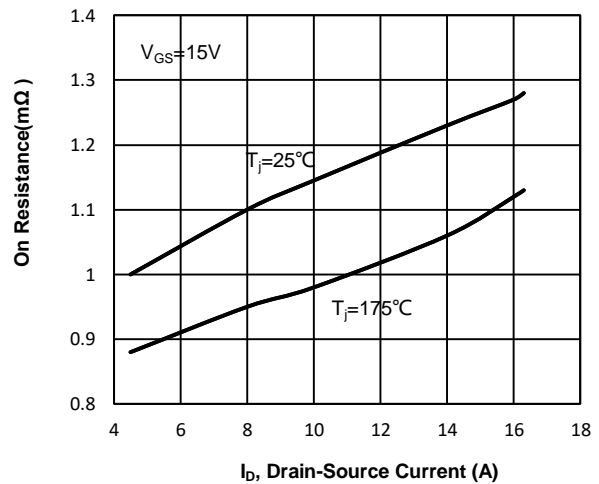
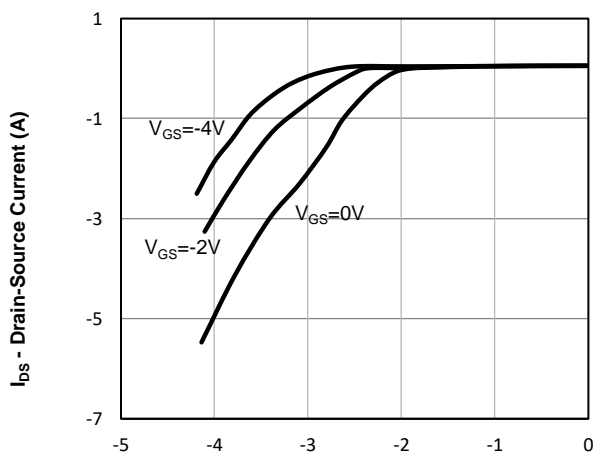
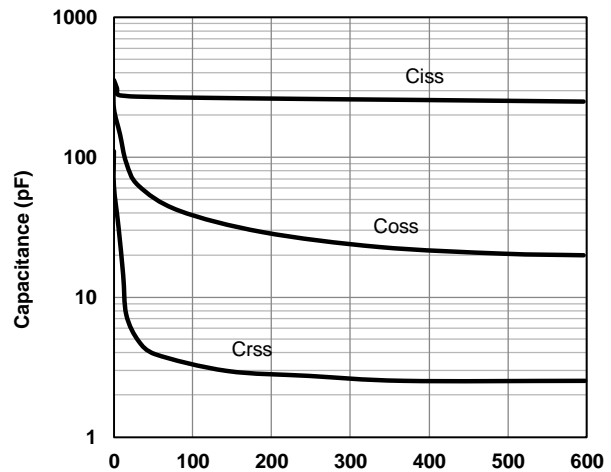
Typical Operating Characteristics

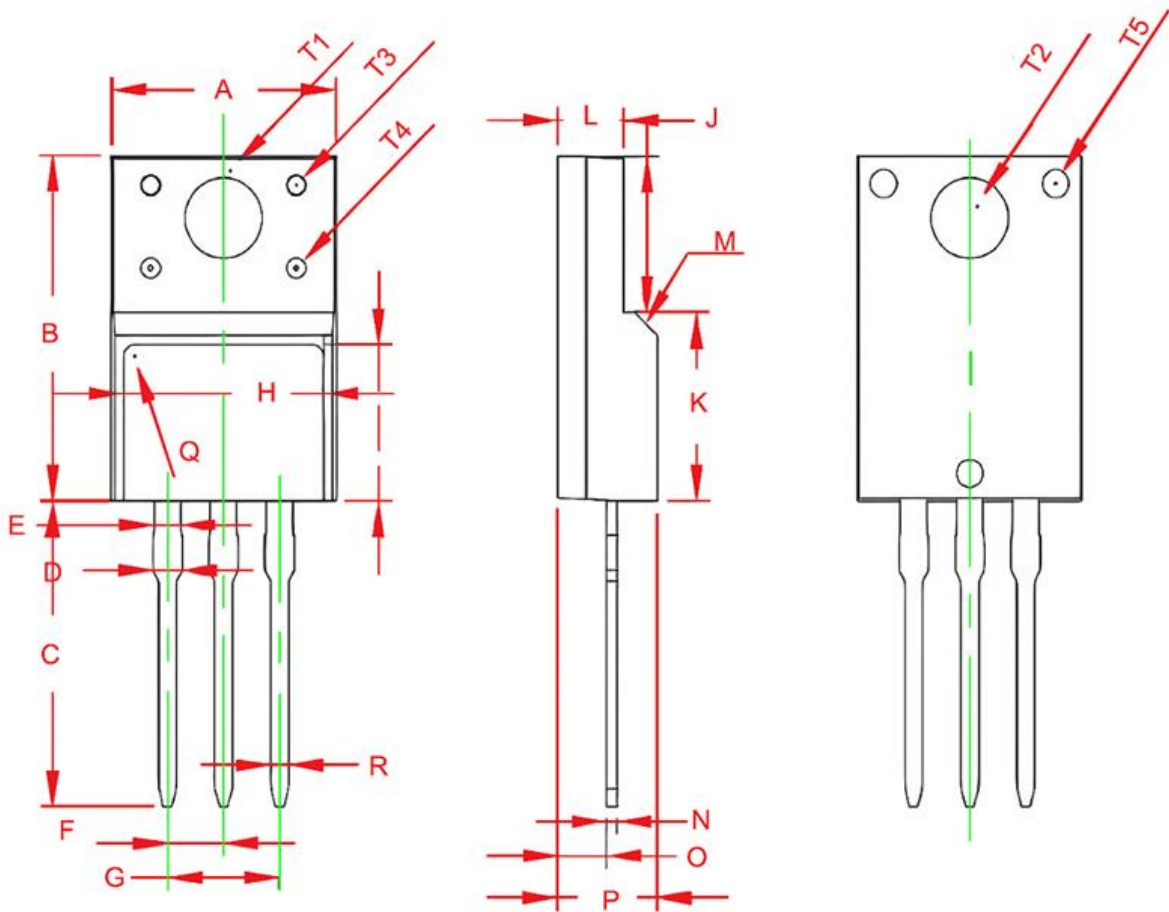
Fig1. Typical Output Characteristics

Fig2. Normalized On-Resistance Vs. Temperature

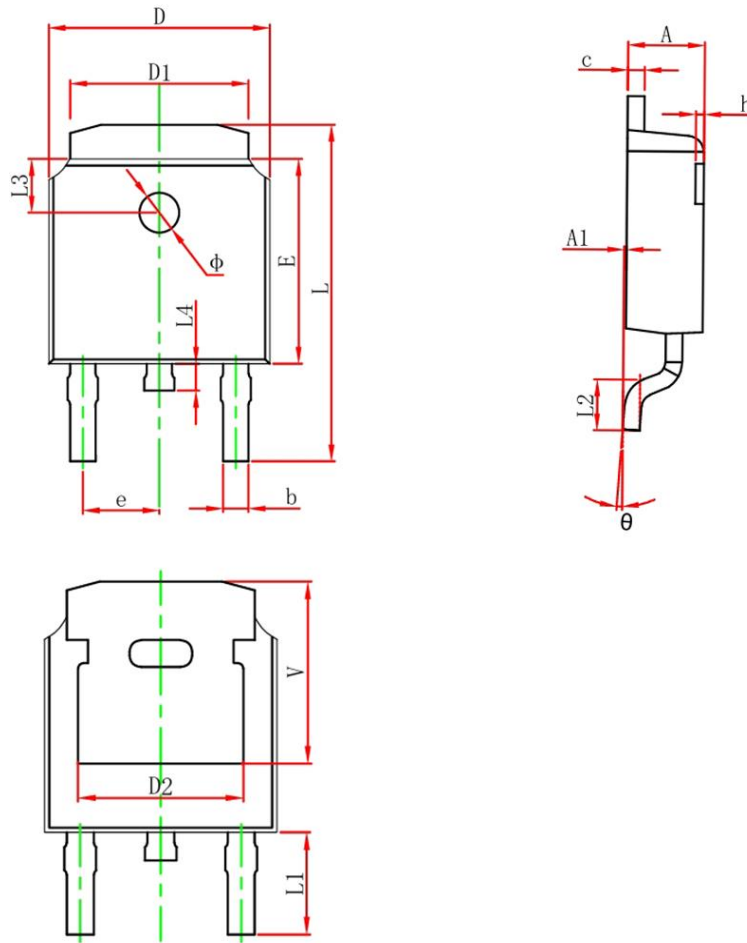
Fig3. Typical Transfer Characteristics

Fig4. On-Resistance Vs. Drain-Source Current

Fig5. Body Diode Characteristics

Fig6 Typical Capacitance Vs. Drain-Source

TO-220F Package information

Symbol	Dimensions in Millimeters(mm)		Dimensions In Inches	
	Min	Max	Min	Max
A	9.960	10.360	0.392	0.407
B	15.670	16.070	0.616	0.632
C	13.140	13.540	0.517	0.533
D	1.200	1.400	0.047	0.055
E	1.200TYP		0.047TYP	
F	2.540TYP		0.100TYP	
G	5.080TYP		0.200TYP	
H	7.600	8.000	0.299	0.314
I	7.100	7.500	0.279	0.295
J	6.480	6.880	0.255	0.270
K	8.990	9.390	0.353	0.369
L	2.340	2.740	0.092	0.107
M	45°TYP		45°TYP	
N	0.490	0.520	0.019	0.020
O	2.150	2.550	0.084	0.100
P	4.500	4.900	0.177	0.192
Q	0.500TYP		0.019TYP	
S	4.5°TYP		4.5°TYP	
T1	3.450TYP		0.135TYP	
T2	3.180TYP		0.125TYP	
T3	1.500TYP		0.059TYP	
T4	1.200TYP		0.047TYP	
T5	1.500TYP		0.059TYP	
R	0.770	0.830	0.030	0.032

TO-252 Package information

Symbol	Dimensions in Millimeters(mm)		Dimensions In Inches	
	Min	Max	Min	Max
A	2.200	2.400	0.087	0.094
A1	0.000	0.127	0.000	0.005
b	0.635	0.770	0.025	0.030
c	0.450	0.580	0.018	0.023
D	6.500	6.700	0.256	0.264
D1	5.100	5.460	0.201	0.215
D2	4.830 REF.		0.190 REF.	
E	6.000	6.200	0.236	0.244
e	2.186	2.386	0.086	0.094
L	9.712	10.312	0.386	0.406
L1	2.900 REF.		0.114 REF.	
L2	1.400	1.700	0.055	0.067
L3	1.600 REF.		0.063 REF.	
L4	0.600	1.000	0.024	0.039
Φ	1.100	1.300	0.043	0.051
θ	0°	8°	0°	8°
h	0.000	0.300	0.000	0.012
V	5.250 REF.		0.207 REF.	